



ECMSa

Installation Guide

November 2021

Document Revision: 3.11.02

ECMsa

Release Date: November 2021

COPYRIGHT

© ACS Motion Control Ltd., 2021. All rights reserved.

Changes are periodically made to the information in this document. Changes are published as release notes and later incorporated into revisions of this document.

No part of this document may be reproduced in any form without prior written permission from ACS Motion Control.

TRADEMARKS

Windows and Intellisense are trademarks of Microsoft Corporation.

Any other companies and product names mentioned herein may be the trademarks of their respective owners.

PATENTS

Israel Patent No. 235022

US Patent Application No. 14/532,023

Europe Patent application No.15187586.1

Japan Patent Application No.: 2015-193179

Chinese Patent Application No.: 201510639732.X

Taiwan(R.O.C.) Patent Application No. 104132118

Korean Patent Application No. 10-2015-0137612

www.acsmotioncontrol.com

support@acsmotioncontrol.com

sales@acsmotioncontrol.com

NOTICE

The information in this document is deemed to be correct at the time of publishing. ACS Motion Control reserves the right to change specifications without notice. ACS Motion Control is not responsible for incidental, consequential, or special damages of any kind in connection with using this document.

Revision History





Date	Revision	Description
October 2021	3.11.01	LED image corrections
August 2021	3.10.02	EtherCAT (TM) on legalese page
June 2021	3.10.01	Add minimum load inductance at 150VDC Wiring: Capacitor between 150V source and Drive supply connector
April 2021	1.00	First release

Conventions Used in this Guide

Text Formats

Format	Description
Bold	Names of GUI objects or commands
BOLD + UPPERCASE	ACSPL+ variables and commands
<code>Monospace + grey background</code>	Code example
<i>Italic</i>	Names of other documents
Blue	Hyperlink
[]	In commands indicates optional item(s)
	In commands indicates either/or items

Flagged Text

	Note - includes additional information or programming tips.
	Caution - describes a condition that may result in damage to equipment.
	Warning - describes a condition that may result in serious bodily injury or death.
	Model - highlights a specification, procedure, condition, or statement that depends on the product model
	Advanced - indicates a topic for advanced users.

Related Documents

Documents listed in the following table provide additional information related to this document. The most updated version of the documents can be downloaded by authorized users from [Downloads](#).

Document	Description
<i>SPiiPlus MMI Application Studio User Guide</i>	Explains how to use the SPiiPlus MMI Application Studio and associated monitoring tools
<i>SPiiPlusES Installation and Operation Guide</i>	Provides installation information

Table of Contents

1. Introduction	10
1.1 Document Scope	10
2. Detailed Description	11
2.1 Package Contents	11
2.2 Connectors	12
2.3 Jumpers	14
2.4 LED Indicators	14
2.5 Optional Accessories	16
2.5.1 Mating Connector Kits	16
2.5.2 STO Breakout Cable	17
2.5.3 SPI Breakout Cable	18
2.5.4 RS232 Adapter Cable	19
2.5.4.1 RS232 Pinout	19
2.6 Ordering Part Number	20
3. Mounting and Cooling	21
4. Connections	23
4.1 Safety, EMC and Wiring Guidelines	23
4.2 Power Supplies	25
4.2.1 Drive Supply	25
4.2.1.1 Drive Supply Guidelines	26
4.2.1.2 Drive Supply Description	27
4.2.1.3 Drive Supply Connection Instructions	27
4.2.2 Control Supply (J11)	27
4.2.2.1 Control Supply Guidelines	27
4.2.2.2 Control Supply Description	28
4.2.2.3 Control Supply Connection Instructions	28
4.3 SPI	28
4.3.1 SPI Description	28
4.3.2 SPI Connection Pinout	29
4.3.3 SPI Software Interface	29
4.4 STO and SS1-t (J1) (Certification Pending)	29
4.4.1 STO Description	30

4.4.2 SS1-t Description	31
4.4.3 STO Connection Instructions	31
4.5 ID Chip Interface	31
4.5.1 ID Chip Interface Description	31
4.6 Ethernet	32
4.6.1 Ethernet Description	32
4.6.2 Ethernet Connection Instructions	33
4.7 I/O Interfaces	34
4.7.1 General I/O	34
4.7.1.1 I/O Description	34
4.7.1.2 I/O Connection Instructions	35
4.7.2 Limits	37
4.7.2.1 Limits Description	37
4.7.2.2 Limits Connection Instructions	38
4.8 Encoder Connectors	39
4.8.1 Encoder Description	39
4.8.2 Encoder Connection Instructions	41
4.8.2.1 Additional Device Connections	44
4.9 Motors	45
4.9.1 Motor Description	45
4.9.2 Motor Connection Instructions	45
5. Product Specifications	48
5.1 EtherCAT Cycle Rate	54
5.2 Dimensions	55
5.3 Weight	55
5.4 Compliance with Standards	55
5.4.1 Environment	55
5.4.2 EMC (Pending)	55
5.4.3 Electrical Safety (Pending)	55
5.4.4 Functional Safety	55

List Of Figures

Figure 2-1. ECMsa Front Panel Connectors	12
Figure 2-2. ECMsa Drive Supply, Motor Supply, Jumpers	13
Figure 2-3. ECMsa STO and Communication Connectors	13
Figure 2-4. STO-ACC1 Breakout Cable	17
Figure 2-5. SPI Breakout Cable	18
Figure 2-6. RS232 Adapter	19
Figure 3-1. Airflow and Mounting	21
Figure 3-2. Dimensions - Rear (mounting side) View	22
Figure 4-1. ECMsa grounding screw	25
Figure 4-2. J13 - Drive Supply Connector	27
Figure 4-3. Control Supply Connections	28
Figure 4-4. J1 - STO Connector	30
Figure 4-5. STO Connections	31
Figure 4-6. Ethernet connection to Ethernet host	33
Figure 4-7. Mark Inputs Connection Diagram	35
Figure 4-8. PEG Outputs Connection Diagram J7-I/O Connector	36
Figure 4-9. Mechanical Brake & GP Digital outputs source connection diagram	36
Figure 4-10. Mechanical Brake & GP Digital Outputs Sink Connection Diagram	37
Figure 4-11. Left and Right Source Connection	38
Figure 4-12. Left and Right Sink Connection	39
Figure 4-13. Incremental Digital Encoder (AqB) Connection	42
Figure 4-14. Absolute Encoder (Data Only) Connection	42
Figure 4-15. Absolute Encoder (CLK-Data) Connection Diagram	43
Figure 4-16. SinCos Connection	43
Figure 4-17. Incremental Digital Encoder (CLK-DIR) Connection	44
Figure 4-18. MTMP Motor Temperature Sensor Connection	44
Figure 4-19. Hall Sensor Inputs Connection	45

List of Tables

Table 2-1. Jumpers	14
Table 2-2. LED Indicators	14
Table 2-3. Connector Kit List	16
Table 2-4. STO-ACC1 Pinout	17
Table 2-5. STO Cable Pinout	18
Table 2-6. Configuration as Indicated by P/N	20
Table 4-1. Connector Assignments	23
Table 4-2. Wiring Guidelines	24
Table 4-3. Fuse Ratings	26
Table 4-4. J13 - Drive Supply Connector Pinout	27
Table 4-5. J11 - Control Supply Pinout	28
Table 4-6. J1 - STO Connectors Pinout	30
Table 4-7. J7 - I/O Connector Pinout	34
Table 4-8. Limits Connector Pinout	37
Table 4-9. Encoder Connector Pinout	40
Table 5-1. System Specifications	48
Table 5-2. Motor Over Temperature Specifications	52
Table 5-3. STO and SS1 (Optional)	52
Table 5-4. RS232	53
Table 5-5. SPI	53
Table 5-6. CTIME Values for ECMsa	54

1. Introduction

1.1 Document Scope

This document describes the installation information for the ECMsa.

This document is intended for the use of engineers and technicians experienced in commissioning motion control systems.

The ECMsa is a member of the Economical Control Modules (ECM) series of compact, highly integrated all-in-one motion controller and drives solutions designed to meet the needs of OEMs with cost-sensitive motion control applications. Its unique multiprocessor architecture leverages powerful control algorithms to achieve best-in-class performance, while its universal servo drive technology enables the system designer to easily control most types of motors and stages.

2. Detailed Description

2.1 Package Contents

The ECMsa package contains the following items:

- > ECMsa
- > Control supply mating connector (for J9): Phoenix MC 1,5/ 3-STF-3,81 BK(1753180)



- > Drive supply mating connector, P/N: Molex 171692-0104



- > Drive supply mating connector pins, P/N: Molex 1720630311
- > STO Connector Kit P/N: STO-ACC2 (supplied only for units ordered with STO, see [STO Breakout Cable](#))

2.2 Connectors

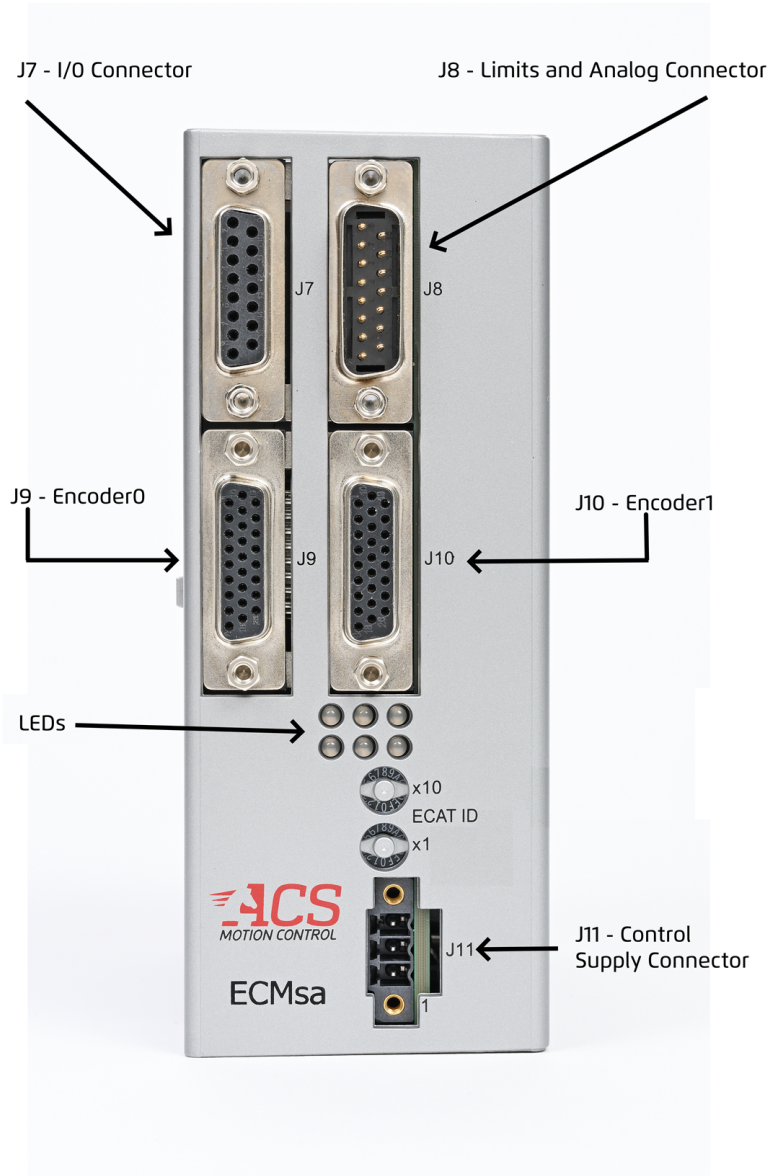

Figure 2-1. ECMsa Front Panel Connectors

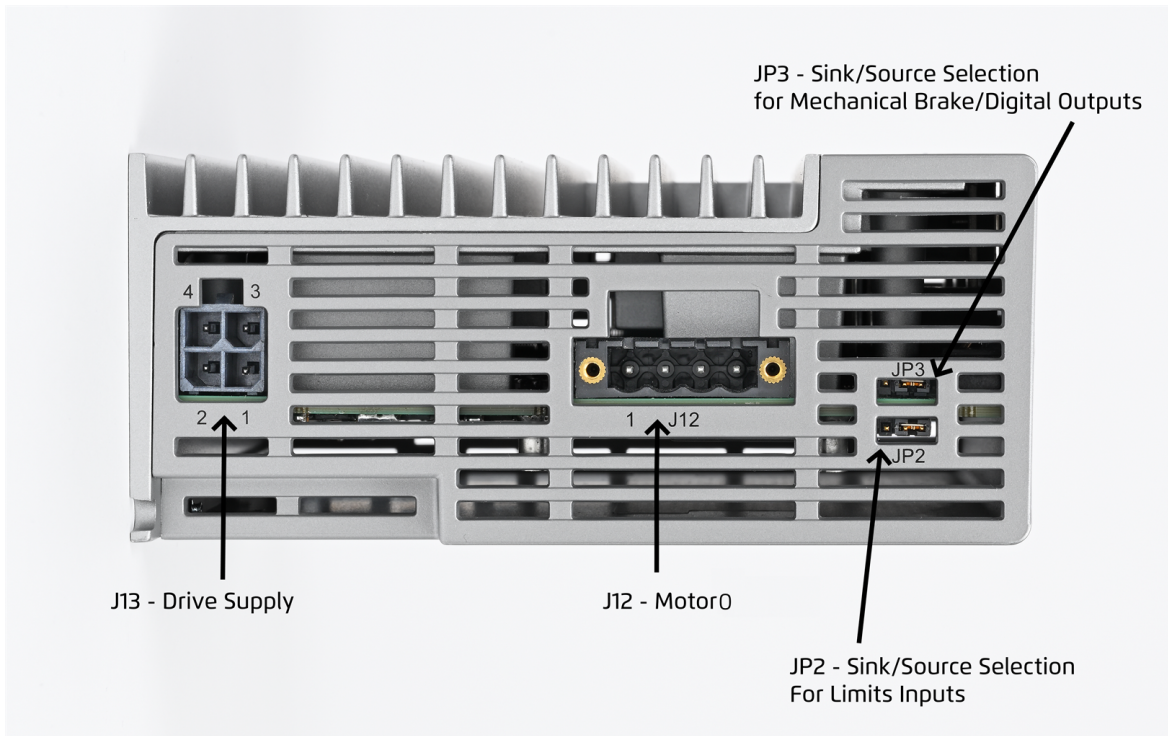

Figure 2-2. ECMsa Drive Supply, Motor Supply, Jumpers

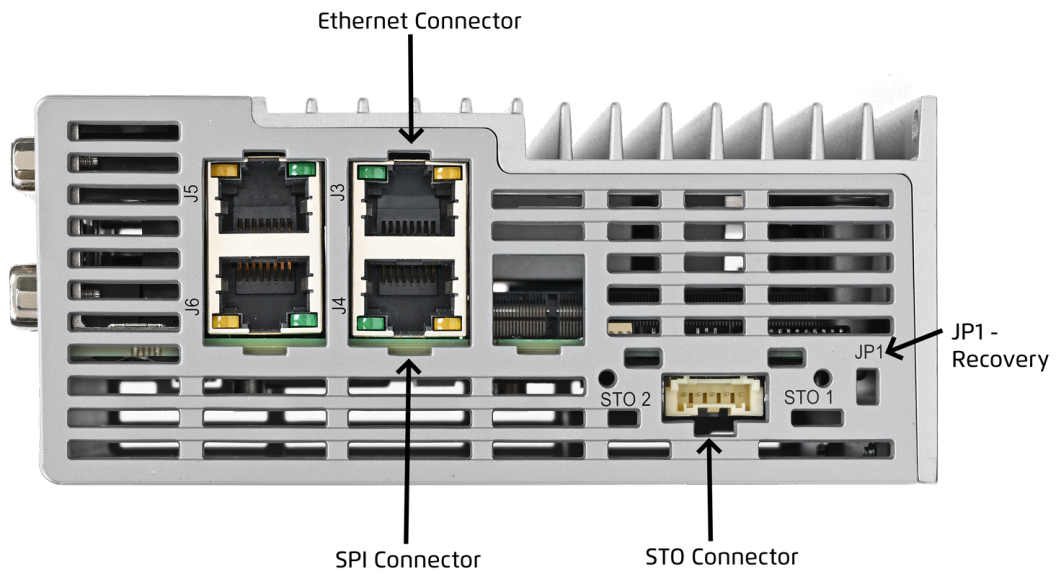

Figure 2-3. ECMsa STO and Communication Connectors

2.3 Jumpers

Table 2-1. Jumpers

Jumper Name	Position 1-2	Position 2-3
JP1 Recovery	FW Recovery Mode	N/A
JP2 - SINK/SOURCE Selection for limits inputs	Source input type	Sink Input Type
JP3 - SINK/SOURCE selection for mechanical brake / digital outputs	Sink Output Type	Source Output Type

2.4 LED Indicators

Table 2-2. LED Indicators

Designator	Description	Note
Control supply	<p>Green</p> <ul style="list-style-type: none"> > Off- Logic supply not connected > On- power supply OK 	
Ethernet Link/Activity	<p>Yellow</p> <ul style="list-style-type: none"> > Off- No link (no connection) > Blinking -Link and activity > On -Link without activity 	<p>Located on the Ethernet RJ45 connector. Right LED.</p>
Ethernet Speed	<p>Green</p> <ul style="list-style-type: none"> > 100Mbit 	<p>Located on the Ethernet RJ45 connector. Left LED.</p>
STATUS External network status	<p>Bicolor</p> <ul style="list-style-type: none"> > Green LED – according to "RUN Indicator" > Red LED – according to "ERROR Indicator" 	<p>According to ETG.1300 S ® V1.1.1</p>

Designator	Description	Note
System	Bicolor > Red – System Fault > Green – System Ok > Blinking Green– Software command	Located on the front
Axis status	Bicolor > Off- axis disabled > Green- axis enabled > Red- fault	
Drive supply	Green > On - drive supply connected.	

The following image indicates the function of the LEDs on the front panel:

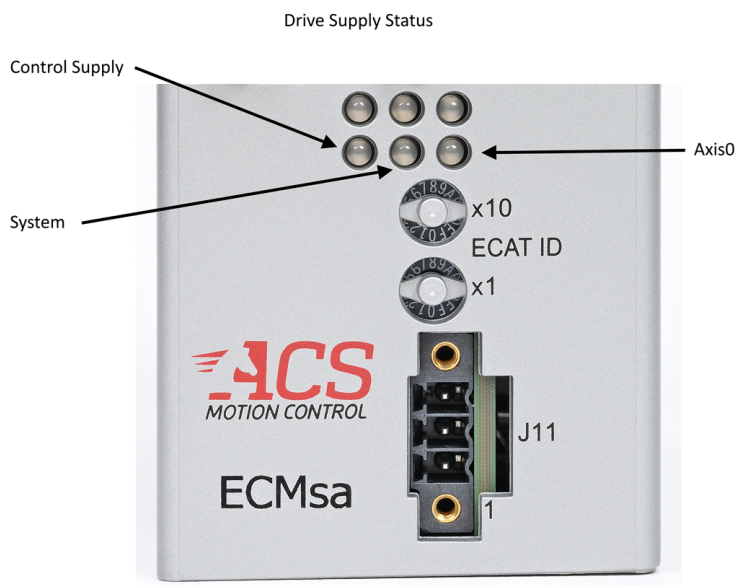

The following image indicates the function of the LEDs for the various communication functions:

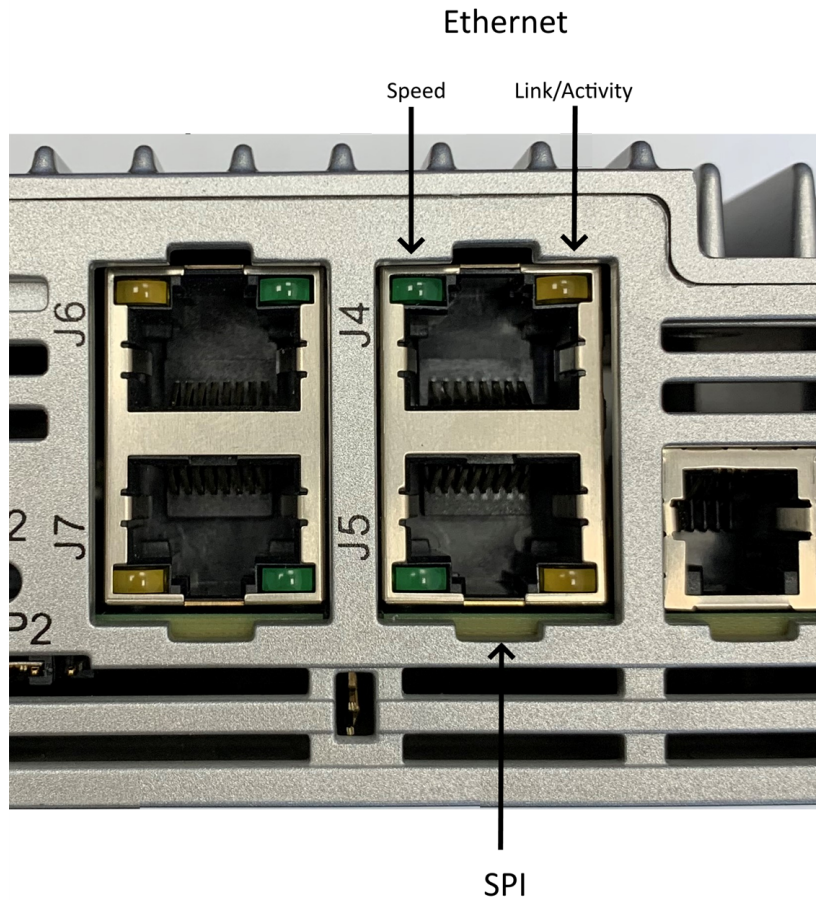

2.5 Optional Accessories

2.5.1 Mating Connector Kits

P/N: XDMsm-ACC1 Mating Connector Kit

Table 2-3. Connector Kit List

Connector	Part Description	Manufacturer	Manufacturer P/N	Quantity
J12-MOTOR0	CONNECTOR	PHOENIX CONTACT	MSTB 2,5 HC/ 4-STF-5,08 BK	1
J11-Control Supply	CONNECTOR	PHOENIX CONTACT	MC 1,5/ 3-STF-3,81 BK	1

Connector	Part Description	Manufacturer	Manufacturer P/N	Quantity
J13-Drive Supply	Molex 171692-0104 Connector Pin	MOLEX	171692-0104 1720630311(Pin)	1
J8-LIMITS (15-pin)	D-type 15 pin female			1
J7-I/O (15-pin)	D-type 15-pin male			1
J9-Encoder0 J10-Encoder1	D-TYPE CUP 26P HI-DNSTY ML NPB	AMPHENOL	G17TH- 2610122EU	2

2.5.2 STO Breakout Cable

P/N: STO-ACC1

Description: 2 meter cable with the STO mating connector on one end and flying leads on the other.



Figure 2-4. STO-ACC1 Breakout Cable

Table 2-4. STO-ACC1 Pinout

Pin	Wire Color	Signal
1	Black	STO1-
2	Red	STO1+

Pin	Wire Color	Signal
3	Yellow	EGND
4	White	STO2+
5	Black	STO2-

2.5.3 SPI Breakout Cable

P/N: SPI-ACC1

Description: 10 meter cable with SPI mating connector on one end, connecting to J4. The other end has flying leads for connection to user equipment.



Figure 2-5. SPI Breakout Cable

Table 2-5. STO Cable Pinout

Pin	Wire Color	Signal
1	Green/White	SPI_MOSI+
2	Green	SPI_MOSI-
3	Red/White	SPI_MISO+
4	Blue	SPI_CLK+
5	Blue/White	SPI_CLK-
6	Red	SPI_MISO-

Pin	Wire Color	Signal
7	Black/White	SPI_SS+
8	Black	SPI_SS-

2.5.4 RS232 Adapter Cable

P/N: 1. RS232-ACC1

Description: Cable with RS232 mating connector on one end and male D-Sub connector on the other.



Figure 2-6. RS232 Adapter

2.5.4.1 RS232 Pinout

	Name	Description
1	N/C	Not Connected
2	RXD	RS-232 Receive signal for communication port 1 (COM1)
3	TXD	RS-232 transmit signal for communication port 1 (COM1)
4	N/C	Not Connected
5	GND	Ground
6	N/C	Not Connected

	Name	Description
7	N/C	Not Connected
8	N/C	Not Connected
9	N/C	Not Connected

2.6 Ordering Part Number

The ordering part number (P/N) contains several characters (see example below) that each specify a configuration characteristic ordered for the ECMsa module, as described in [Table 2-6](#).

Table 2-6. Configuration as Indicated by P/N

Ordering Options	Field	Example User Selection	Values
Controller & Drive Axes	1	1	1
Current and Bus Voltage Rating	2	C	A = 2.5/5A up to 150VDC B = 5/10A up to 150VDC C=10/20A up to 150VDC D=15/30A up to 100VDC
500 kHz SinCos Encoder Channels	3	1	0, 1, 2
Absolute Encoder Channels	4	1	0, 1, 2
Functional Safety	5	T	N=None, T=STO & SS1
Reserved for Future	6	N	N
Reserved for Future	7	N	N
Reserved for Future	8	N	N
Reserved for Future	9	N	N
Reserved for Future	10	N	N

For an explanation of the non-linear control feature please see the *Non-linear Control Application Note*, available on the ACS website (www.acsmotioncontrol.com) or with the ADK installation documentation.

Example: ECMsa-1C11T-NNNNN

Description: 10/20A, 1 channel 500kHz SinCos, 1 channel absolute encoder, STO & SS1

Field	1	2	3	4	5	6	7	8	9	10
PN	ECMSA	1	C	1	1	T	N	N	N	N

3. Mounting and Cooling

- > Unit must be mounted vertically when working with forced airflow, using M4 type Philips screws. The dimensions (in millimeters) are shown below.
- > Leave sufficient clearance of 50 millimeters on all open sides for cable routing and free airflow.
- > Unit operates in the ambient temperature range of 0 to 50°C.

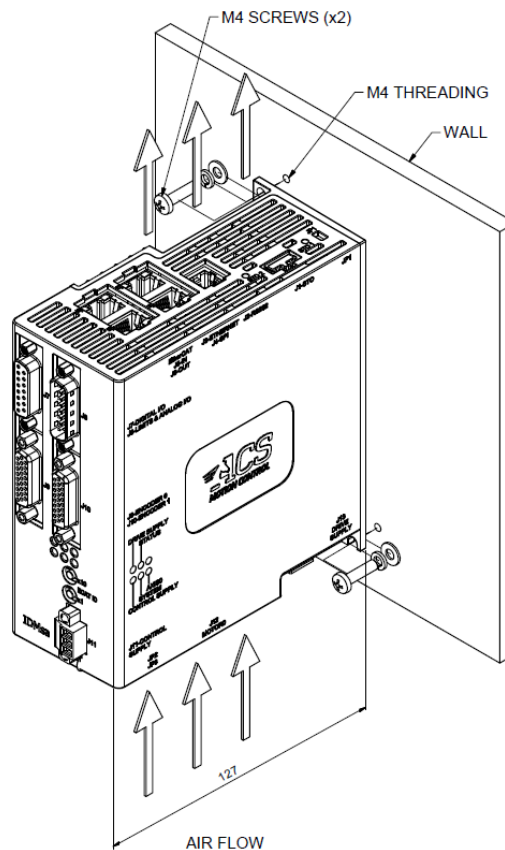

Figure 3-1. Airflow and Mounting



This image is for illustrative purposes, and might not match the exact device described in this document.

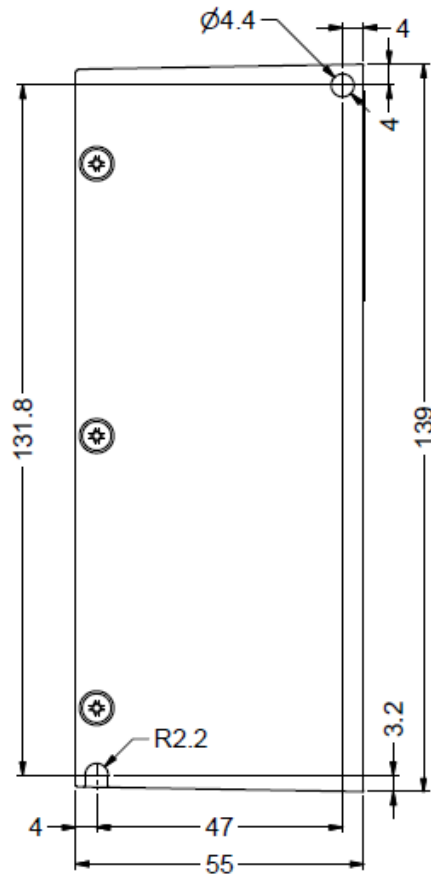

Figure 3-2. Dimensions - Rear (mounting side) View

4. Connections

This section describes how to interface with the ECMsa using proper safety, EMC and wiring guidelines.

Table 4-1. Connector Assignments

Connector assignment	Connector name	Mating connector
J1	STO	JST 5 PIN 2mm female PAP-05V-S Pin type: SPHD-001T-P0.5
J2	RS232	RJ11 plug 4 positions 4 contacts
J3	Ethernet	RJ45 plug 8 positions 8 contacts
J4	SPI	RJ45 plug 8 positions 8 contacts
J7	I/O	D-type 15 male
J8	LIMITS & Analog	D-type 15 pin female
J9	Encoder0	D-type 26 pin high density male
J10	Encoder1	D-type 26 pin high density male
J11	Control supply	Phoenix MC 1,5/ 3-STF-3,81
J12	MOTOR0	MSTB 2,5 HC/ 4-STF-5,08
J13	DRIVE SUPPLY	Molex 171692-0104 Pin: Molex 1720630311

4.1 Safety, EMC and Wiring Guidelines

Read this section carefully before beginning the installation process.

An STO module (Safe Torque Off) is an optional feature of the unit. Additional information can be found in [STO and SS1-t \(J1\) \(Certification Pending\)](#).

Installation and maintenance must be performed only by qualified personnel who have been trained and certified to install and maintain high power electrical and electro-mechanical equipment, servo systems, power conversion equipment and distributed networks.

To avoid electric arcing and hazards to personnel and electrical contacts, avoid connecting and disconnecting the ECMsa while the power source is on.

When connecting the ECMsa to an approved isolated control and drive supply, connect it through a line that is separated from hazardous live voltages using reinforced or double insulation, in accordance with approved safety standards.



The ECMsa is not intended for use in safety-critical applications (such as life support devices) where a failure of the ECMsa can reasonably be expected to cause severe personal injury or death.



J12 and J13 contain hazardous voltages of up to 150V PWM modulated.

Perform the following instructions to ensure safe and proper wiring:

- > Whenever possible, use shielded cables with braided shield of at least 80%-95% coverage.
- > Follow the guidance of below, based on the current rating of your ECMsa.
- > Proper wiring, grounding and shielding are essential for ensuring safe, dependable, and optimal servo performance. After completing the wiring, carefully inspect all wires to ensure tightness, good solder joints, and general safety.

Table 4-2. Wiring Guidelines

Item	Gauge	Twisted pair
Control power supply	18AWG	No
Encoders	28AWG (up to 0.6A), 26AWG (up to 1A)	Yes



Connecting or disconnecting the motor without disabling the drive first can potentially damage the drive.



If the cable from the user's 150v drive supply to the IDMsa is more than 1 meter, a capacitor of 4400 μ F (typically) should be added. It should be as close as possible to the drive supply connector.



Figure 4-1. ECMsa grounding screw

Ground the ECMsa using a M4x6 screw.

4.2 Power Supplies

The unit is fed by two power supplies:

- > Drive Supply: 12 to 150Vdc (J13)
- > Control Supply: 24Vdc (J11)

The power supplies must be provided by the customer and be UL certified.

The supplies can be switched on and off in any order. During emergency situations, the drive supply can be disconnected while the control supply should remain connected.

4.2.1 Drive Supply

An external isolated 12Vdc to 150Vdc power supply (not included with the unit) feeds the drives and the motors.

The drive supply must be connected to the unit via fuse. The fuse rating should be calculated according to the total input current of the unit and should not exceed the ratings in the table.

The drive supply must be able to provide the peak current or inductance load required by the motor. An external capacitor of 4400 μ F can answer this need.

Table 4-3. Fuse Ratings

Driver	Ampere Rating	Voltage Rating	Interrupted Rating DC	Class	Example
2.5/5A	10A	250V	2Ka	K5	ONLN010.T from Littelfuse
5/10A	20A				ONLN020.T from Littelfuse
10/20A	30A				ONLN020.T from Littelfuse
15/30A	40A				ONLN040.T from Littelfuse

4.2.1.1 Drive Supply Guidelines

When selecting the drive power supply, use the following guidelines:

- > The power supply must be isolated.
- > The power supply must be CE and UL approved.
- > The power supply must be short circuit protected.
- > Make sure the power supply can absorb the regeneration energy from the motor when it decelerates. Otherwise an external regeneration circuit is needed.
- > The power supply must be able to provide the peak current required by the motor (inductance load). Adding an external capacitor of 4400 μ F, installed as close as possible to the drives, can help the power supply to handle the peak current and reduce the bus current ripple.
- > The power supply must be selected based on the power consumed by the drives.
- > An example of a suitable 150V power supply is the CSP-3000-250 from Mean Well.

4.2.1.2 Drive Supply Description

Label: J13 DRIVE SUPPLY

Mating type: Molex 171692-0104

Pin P/N: Molex 1720630311



Figure 4-2. J13 - Drive Supply Connector

Table 4-4. J13 - Drive Supply Connector Pinout

Pin	Signal	Description
1	PE	Electrical Ground
2	PE	Electrical Ground
3	VP+	Drive supply positive edge
4	VP-	Drive supply return

4.2.1.3 Drive Supply Connection Instructions

1. Use a low inductance cable with a minimum gauge of 14- AWG.
2. Route the drive supply and motor cables as far as possible from all other noise sensitive cables (such as encoders and I/O).
3. Connect a fast active fuse between the unit and the external power supply.
4. If required, connect the External Regeneration Resistor.
5. Connect the unit PE (Protective Earth) to the power supply PE point.

4.2.2 Control Supply (J11)

An external 24Vdc isolated power supply (not included with the unit) feeds all logic and control low voltage circuitry.

This power supply should remain active (on) even during emergency stop situations, thus ensuring the continuing operation of the network, the controller, the feedback sensors and I/Os.

4.2.2.1 Control Supply Guidelines

When selecting the control power supply, use the following guidelines:

- > The power supply must be isolated.
- > The power supply must be CE and UL approved.
- > The power supply must be short circuit protected.

4.2.2.2 Control Supply Description

Label: 24V CONTROL SUPPLY

Mating Connector: Phoenix MC 1,5/ 3-STF-3,81 -BK

Table 4-5. J11 - Control Supply Pinout

Pin	Name	Description
1	24VDC	+24V dc control supply
2	24V_RTN	24V dc control supply return
3	SHIELD	Electrical Ground

4.2.2.3 Control Supply Connection Instructions

- > Use a shielded cable with a minimum gauge of 18 AWG.

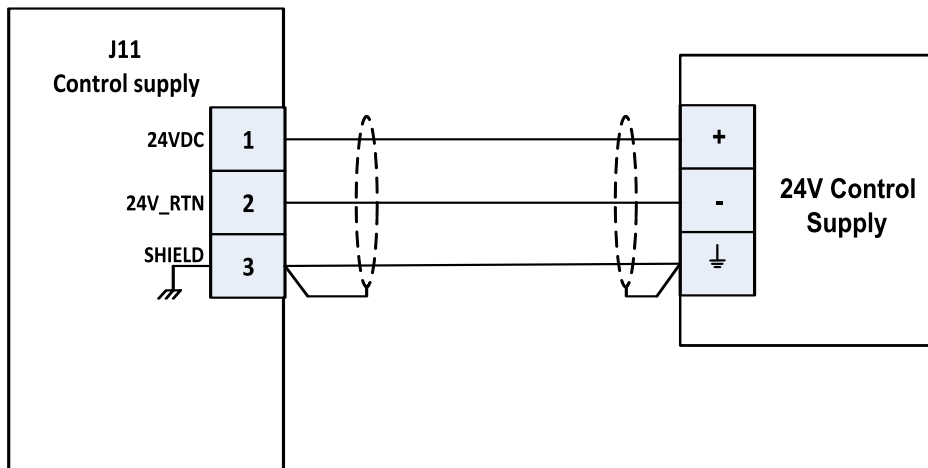

Figure 4-3. Control Supply Connections

4.3 SPI

4.3.1 SPI Description

Label: J4 SPI

Connector: CAT 5e cable with flying leads

P/N: CB-20800-100/LF

Connector name	SPI
----------------	-----

Connector assignment	J4
Manufacturer part number or type	RJ45 socket 8 positions 8 contacts, shielded, CAT 5e
Mating type	RJ45 plug 8 positions 8 contacts

4.3.2 SPI Connection Pinout

	Name	Description
1	SPI_MOSI+	SPI data master output / slave input non inverted
2	SPI_MOSI-	SPI data master output / slave input inverted
3	SPI_MISO+	SPI data master input / slave output non inverted
4	SPI_CLK+	SPI clock non inverted (bi-directional interface for master and slave mode)
5	SPI_CLK-	SPI clock inverted (bi-directional interface for master and slave mode)
6	SPI_MISO-	SPI data master input / slave output inverted
7	SPI_SS+	SPI slave select non inverted (bi-directional interface for master and slave mode)
8	SPI_SS-	SPI slave select inverted (bi-directional interface for master and slave mode)
	SHIELD	Connector shell

The SPI is a high-speed synchronous serial interface, allows a serial bit stream of programmed length to be shifted into and out of the drive.

The SPI is normally used for communications between the ACS drive and external peripherals.

The SPI can be configured as master or slave, up to 8 words of 16 bits. For more information refer to the section on SPI support in the *ACSPL+ Programmer's Guide*.

4.3.3 SPI Software Interface

The ACSPL+ programming language supports SPI data communication through the use of the **SPICFG**, **SPIRXN**, **EXTOUT**, and **EXTIN** commands. For further details see the descriptions of the commands in the *ACSPL+ Commands and Variables Guide* and the section on the SPI interface in the *ACSPL+ Programmer's Guide*.

4.4 STO and SS1-t (J1) (Certification Pending)

The Safe Torque Off module is intended for use in safety applications up to and including SIL-3 according to:

- > EN/IEC 61800-5-2 Ed. 2 (second environment)

- > EN/ IEC 61800-5-1
- > IEC 61508
- > IEC 62061

Performance Level PLe and Category 3 according to:

- > EN ISO 13849-1/-2



STO is an ordering option.

The STO (Safe Torque Off) inputs should be connected to a 24V (18Vdc to 33Vdc) source to enable the drives to generate current and feed the motors. When the 24V is removed from one or both STO inputs, the PWM signals to the power stages are blocked within 40-460msec. In addition, the controller is informed about this event within a few milliseconds. This delay (between informing the controller and blocking of the PWM signals of the drive) provides the controller the ability to bring all axes to a complete stop or slow velocity movement in an orderly manner. The implementation of the STO guarantees that under any foreseen circumstances, failure or damage, any of following types of motors will not move:

- > AC synchronous (DC brushless)
- > Step motor
- > AC asynchronous (AC induction)

4.4.1 STO Description

Label: J1 STO

Mating connector: 5 pin 2mm female by JST P/N PAP-05V-S; Pin: SPHD-001T-P0.5

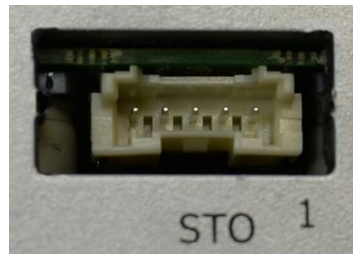

Figure 4-4. J1 - STO Connector

Table 4-6. J1 - STO Connectors Pinout

Pin	Signal	Description
1	STO1-	STO input 1 inverted input
2	STO1+	STO input 1 non inverted input
3	NC	Not connected
4	STO2+	STO input 2 non inverted input

Pin	Signal	Description
5	STO2-	STO input 2 inverted input

4.4.2 SS1-t Description

The SS1-t function provides a delay time between the emergency stop request and the point at which the drive is switched to the torque off mode (STO). During this time the motor will be decelerated by the controller to zero speed. It is important to mention here, that SS1-t does not monitor the deceleration ramp of the drive. The intention of using the SS1-t instead of the pure STO function is to decrease the time which the drive requires to reach standstill.

The delay time is in the range of 40ms to 460ms, depending on the input supply voltage. For 24V STO input supply the delay time is 110 – 230mSec. If the delay is outside this range the collector generates a fault and disables the drive. The deceleration of the motors due to STO/SS1 is not automatic and requires a special user application.

For more details refer to the *ECMsa Safety Manual*.

4.4.3 STO Connection Instructions

The STO1 and STO2 are typically connected to a 24V source via an industry standard safety switch. This device disconnects the 24V upon opening a door, a light current tripping, or other safety related event. Details for handling STO are provided in the *Safe Torque Off Function Application Note*.

The STO circuit draws up to 50mA per STO input, with an inrush current of less than 70mA.

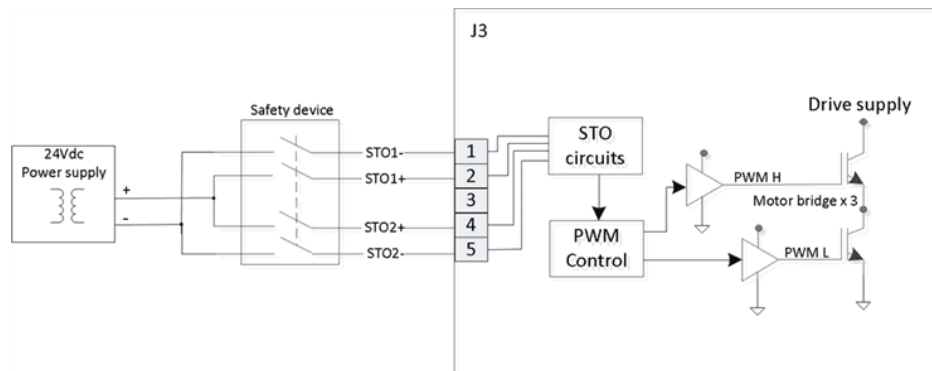

Figure 4-5. STO Connections

4.5 ID Chip Interface

4.5.1 ID Chip Interface Description

The ID Chip interface is a 1-Wire communication interface for automatically identifying parameters of stages supporting the feature

Connector: Pin 21 on encoder connector

Items	Description	Remarks
Designation	ID Chip	

Items	Description	Remarks
Quantity		
Mode	Master	
Interface	1-wire serial protocol using a single data line plus ground reference for communication	

Contact ACS for more details

4.6 Ethernet

4.6.1 Ethernet Description

Label: J3 Ethernet

Connector: RJ45 socket 8 positions 8 contacts, shielded, CAT 5e

Mating Connector: RJ45 plug 8 positions 8 contacts

	Name	Description
1	TD+	Positive transmit signal
2	TD-	Negative transmit signal
3	RD+	Positive receive signal
4	NC	Not connected
5	NC	Not connected
6	RD-	Negative receive signal
7	NC	Not connected
8	NC	Not connected

The Ethernet connector is illustrated in the image below:

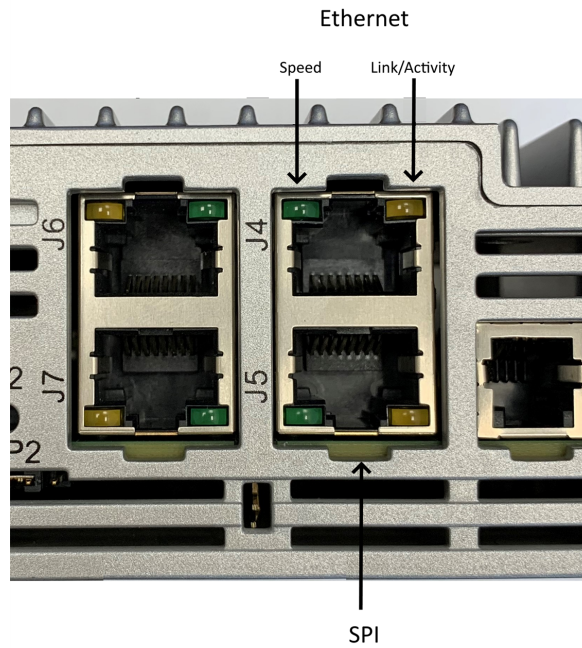

4.6.2 Ethernet Connection Instructions

The following diagram illustrates the connection from the ECMsa to an Ethernet host.

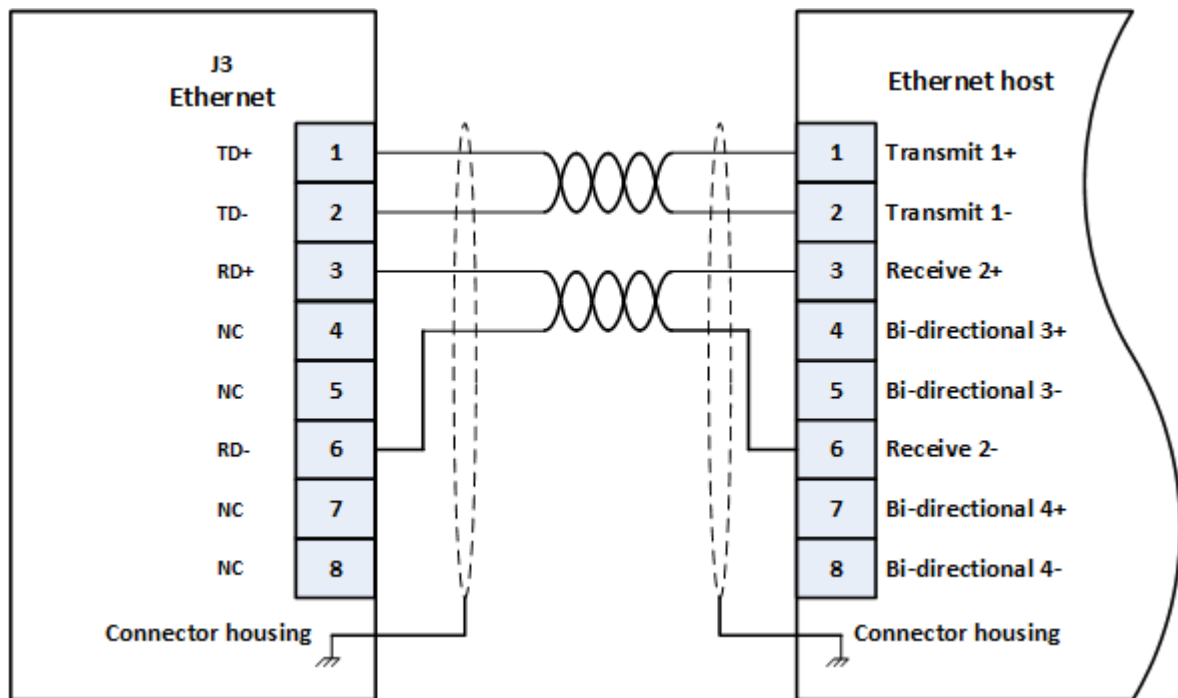

Figure 4-6. Ethernet connection to Ethernet host

4.7 I/O Interfaces

4.7.1 General I/O

4.7.1.1 I/O Description

Label: J7

Mating connector: D-type 15 pin male

Table 4-7. J7 - I/O Connector Pinout

	Name	Description
1	PEG0+	PEG 0 output non inverted
2	PEG1+	PEG 1 output non inverted (not supported)
3	DGND	Digital ground
4	V_SUP_IO	Supply for the IO
5	OUT0	Mechanical brake 0 or Digital output 0
6	NC	Not connected
7	MARK0-	Axis 0 mark input inverted
8	MARK1-	Axis 1 mark input inverted (GP Input 1)
9	PEG0-	PEG 0 output inverted
10	PEG1-	PEG 1 output inverted (not supported)
11	NC	Not connected
12	V_RTN_IO	Supply return for the IO
13	OUT1	Mechanical brake 1 or Digital output 1
14	MARK0+	Axis 0 mark input non inverted
15	MARK1+	Axis 1 mark input non inverted (GP Input 1)

4.7.1.2 I/O Connection Instructions

The I/O connector, J7, can be configured to support Mark inputs, as indicated in the following diagram. See [Registration MARK Inputs or GP Digital Inputs](#) for details.

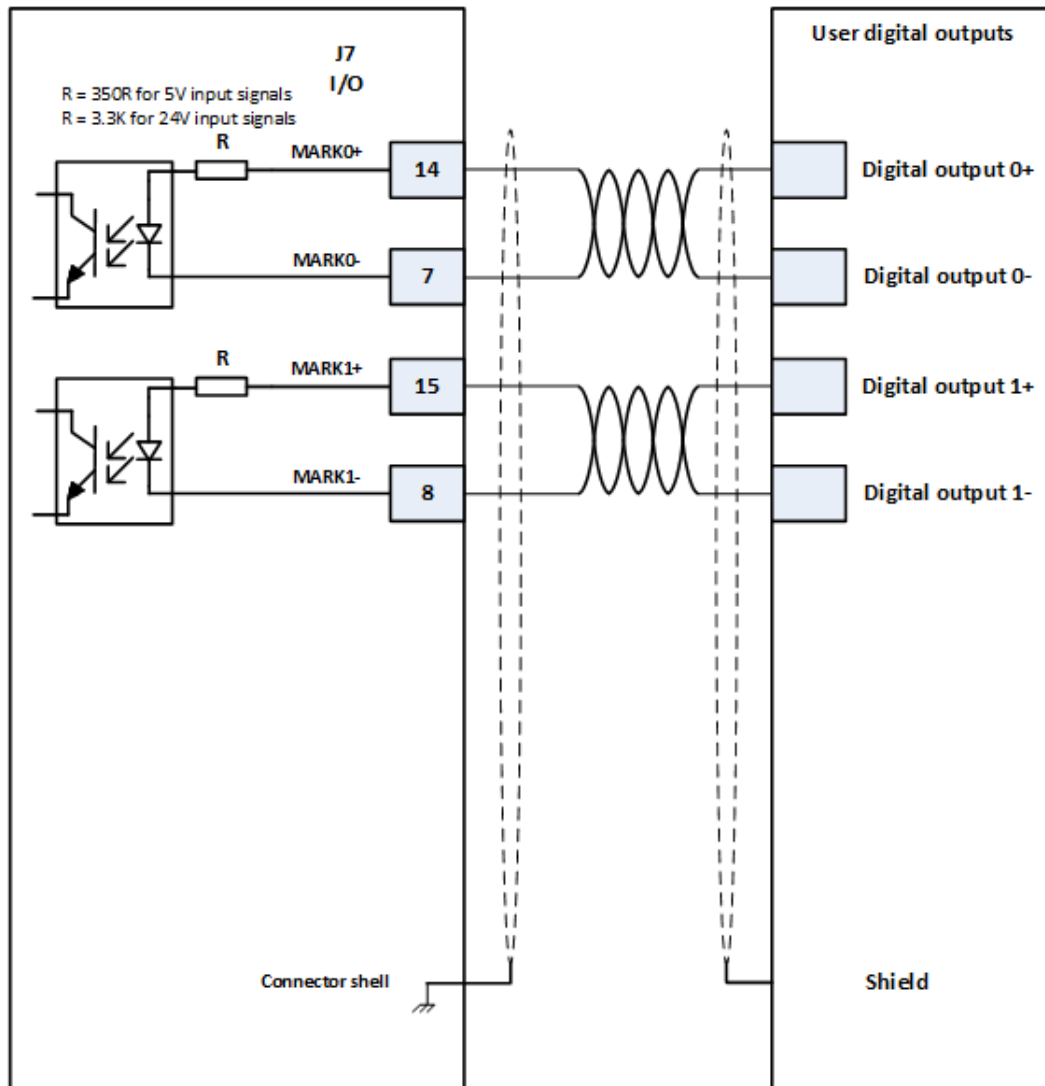

Figure 4-7. Mark Inputs Connection Diagram

J7 can also be used to support PEG outputs, as indicated in the following diagram. See [PEG \(Position Event Generator\)](#) for more details.

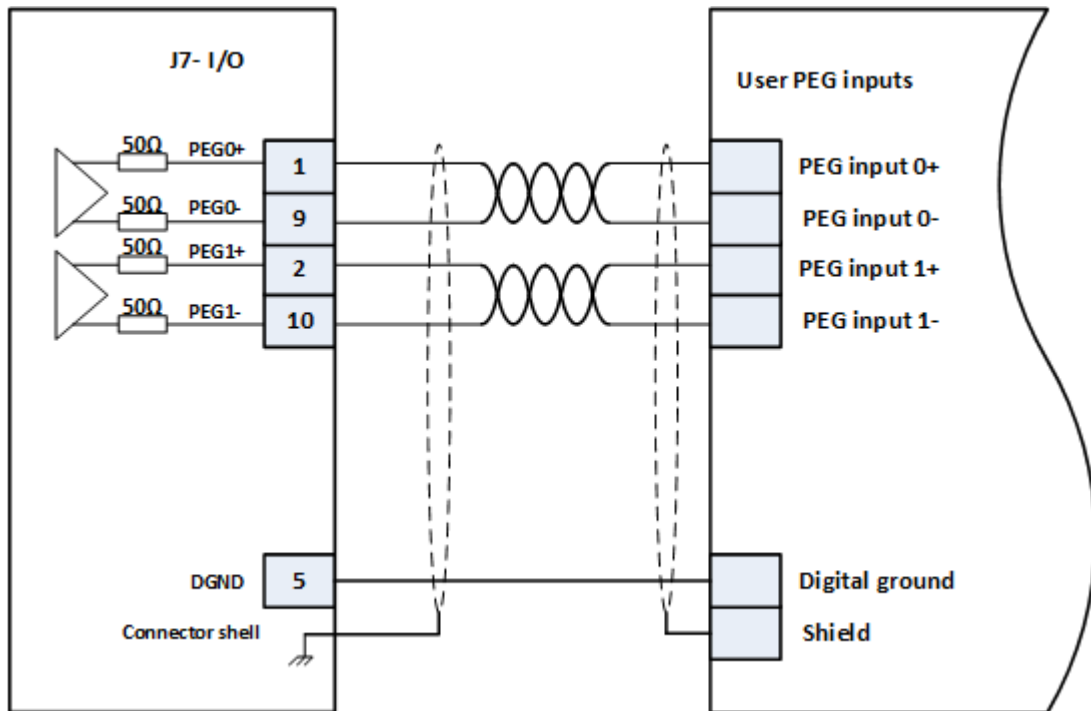

Figure 4-8. PEG Outputs Connection Diagram J7-I/O Connector

J7 can also implement wiring for mechanical brakes and GP digital outputs in a source configuration.

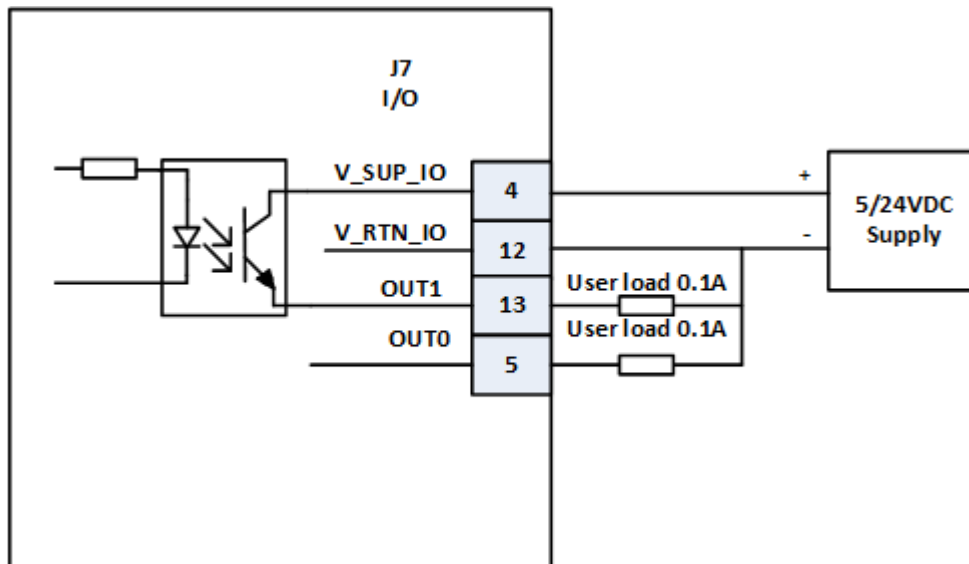

Figure 4-9. Mechanical Brake & GP Digital outputs source connection diagram

The connector can also be configured for the same purpose in a sink configuration.

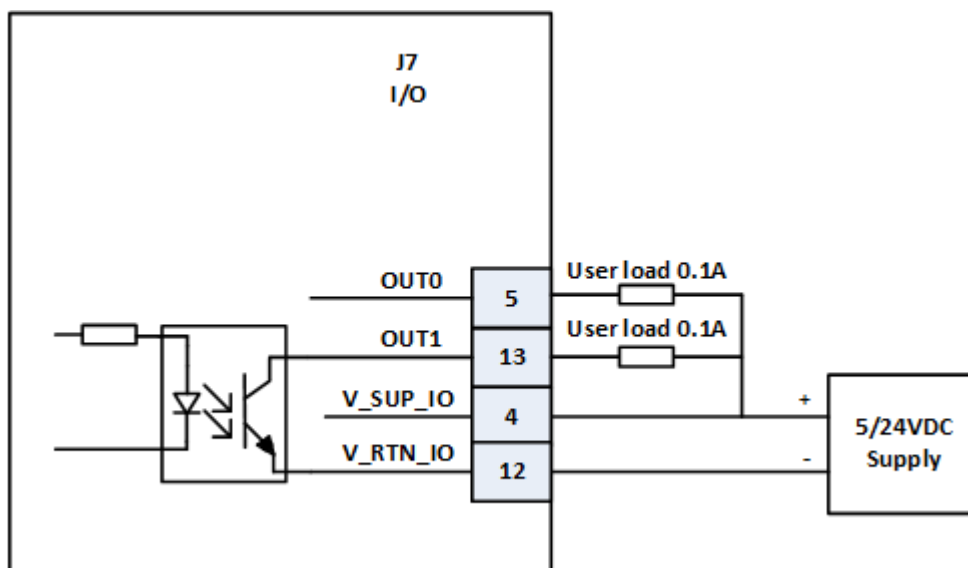

Figure 4-10. Mechanical Brake & GP Digital Outputs Sink Connection Diagram



The device automatically detects whether the power source is 5VDC or 24VDC and adjusts its voltage supply handling accordingly.

4.7.2 Limits

4.7.2.1 Limits Description

Label: J8 LIMITS

Mating Connector: D-type 15 pin female

Table 4-8. Limits Connector Pinout

	Name	Description
1	V_SUP_SFTY	Safety Supply
2	O_LL	Axis 0 left limit
3	NC	Not Connected
4	SA_MODE	Standalone mode, not supported
5	AGND	Analog ground
6	AIN0-	Analog input 0 inverted signal
7	NC	Not connected

	Name	Description
8	AOUT0-	Analog out 0 inverted signal
9	V_RTN_SFTY	Safety supply return
10	O_RL	Axis 0 right limit
11	DGND	Digital ground
12	NC	Not connected
13	AIN0+	Analog input 0 non-inverted signal
14	NC	Not connected
15	AOUT0+	Analog out 0 non-inverted signal

4.7.2.2 Limits Connection Instructions

The following diagrams specify the configuration of the limits controller for various possible configurations.

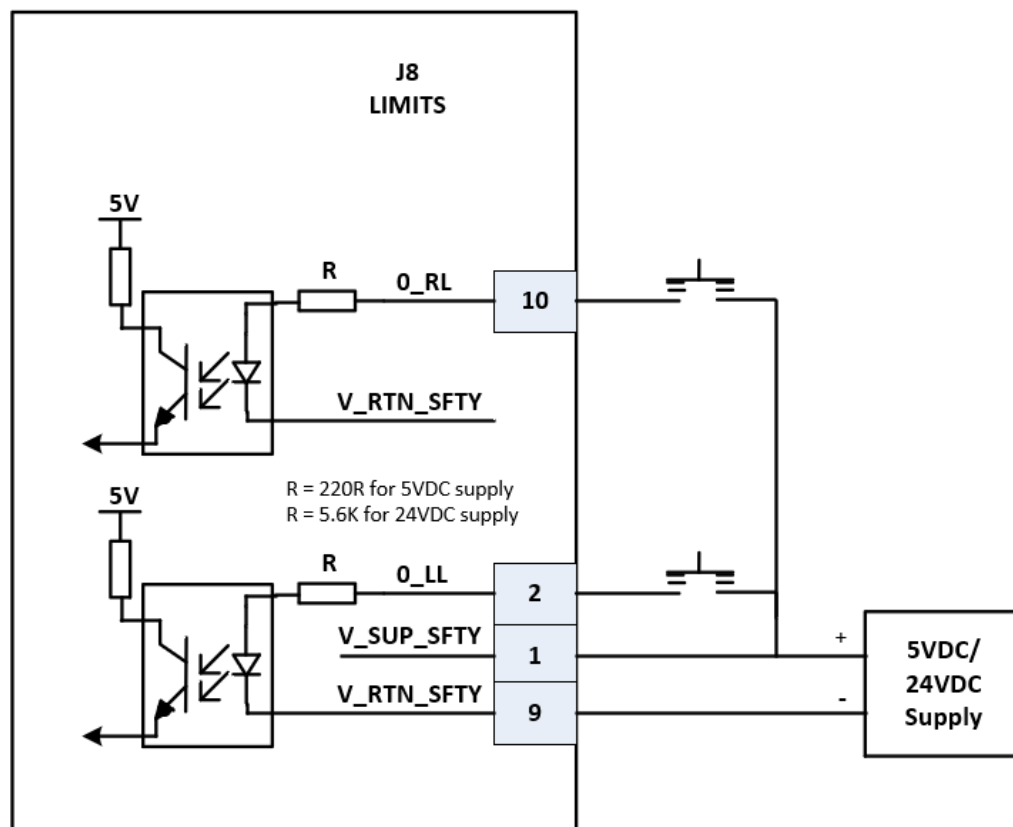

Figure 4-11. Left and Right Source Connection

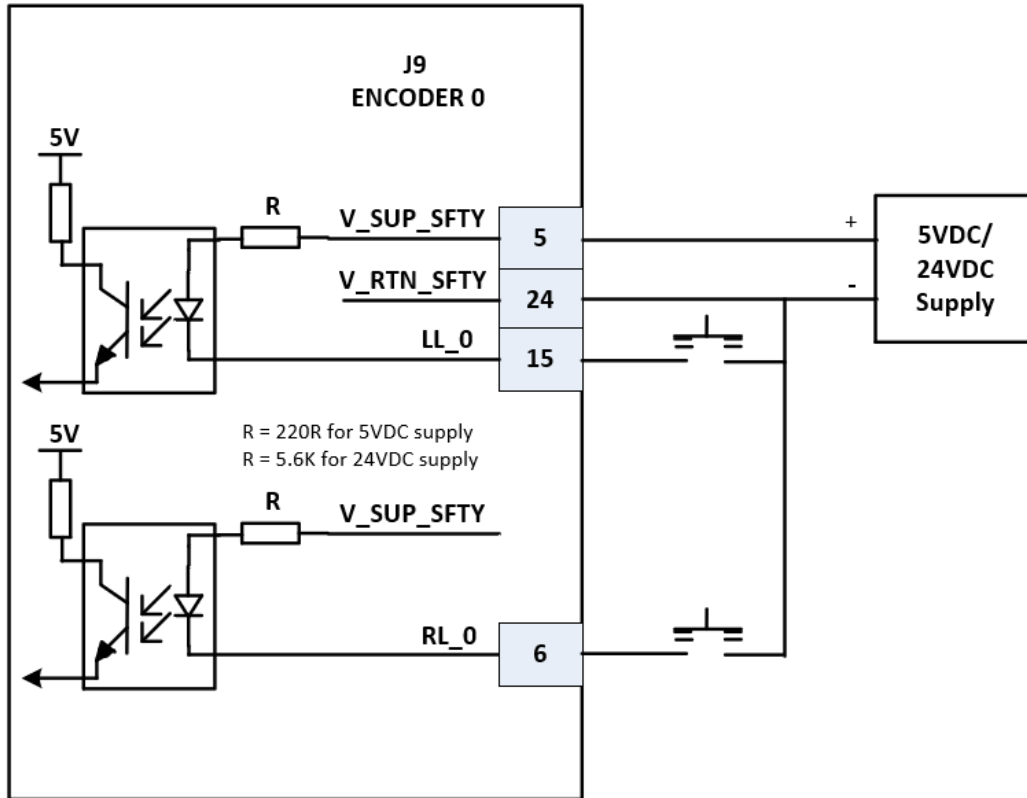

Figure 4-12. Left and Right Sink Connection



The device automatically detects whether the power source is 5VDC or 24VDC and adjusts its voltage supply handling accordingly.

4.8 Encoder Connectors

4.8.1 Encoder Description

Connector Name	Encoder
Connector Assignment	Encoder 0 J9 Encoder 1 J10
Mating Connector	D-type 26 pin high density male

Table 4-9. Encoder Connector Pinout

	Name	Description
1	\$_CHA-/ SQR_SIN\$_-	\$ digital encoder, channel A inverted input, for differential encoder only. Absolute encoder Data-. Squared SIN inverted output.
2	\$_CHB-/ SQR_COS\$_-	\$ digital encoder, channel B inverted input for differential encoder only. Absolute encoder CLK-. Squared COS inverted output.
3	\$_CHI-	\$ digital encoder, channel I (index) inverted input for differential encoder only.
4	\$_HB	\$ Motor Hall B
5	V_SUP_ SFTY	Supply for limits input.
6	\$_RL	Right limit
7	\$_SIN-	\$ Encoder SIN inverted input
8	\$_COS-	\$ Encoder COS inverted input
9	\$_SC_I-	\$ Encoder SIN-COS Index inverted input
10	\$_CHA+/ SQR_SIN\$_+	\$ digital encoder, channel A non-inverted input, used for differential encoders. Absolute encoder Data+. Squared SIN non inverted output.
11	\$_CHB+/ SQR_COS\$_+	\$ digital encoder, channel B non-inverted input, used for differential encoders Absolute encoder CLK+. Squared COS non inverted output.
12	\$_CHI+	\$ digital encoder, channel I (index) non inverted input, used for differential encoders
13	X_HA	\$ Motor Hall A
14	X_HC	\$ Motor Hall C
15	\$_LL	Left limit

	Name	Description
16	\$_SIN+	\$ SIN non inverted input
17	\$_COS+	\$ Encoder COS non inverted input
18	\$_SC_+	\$ Encoder SIN-COS Index non inverted input
19	5U	5V user supply for digital encoder and Hall
20	5U_RTN	5V return user supply for digital encoder, A return for \$ Motor temperature sensor and Hall
21	ID_chip	Bidirectional interface with 1-wire slave devices
22	MTMP_#	MTMP Motor temperature sensor
23	MTMP_#_RTN	Return supply for MTMP
24	V_RTN_SFTY	A return for limits input.
25	5F	5V user supply for analog encoder and Hall
26	5F_RTN	5V return user supply for analog encoder and Hall
	SHIELD	Connector shell and front screw



Pin number 21 in the encoder connector is used for ID Chip. Leave this pin unconnected if the ID chip is not used. This pin should not be connected to shield or ground.

4.8.2 Encoder Connection Instructions

The following tables specify the encoder connections for the various possible configurations.



Combining an absolute encoder with an incremental TTL encoder is not supported. Other combinations may be supported. For further information, contact ACS support.

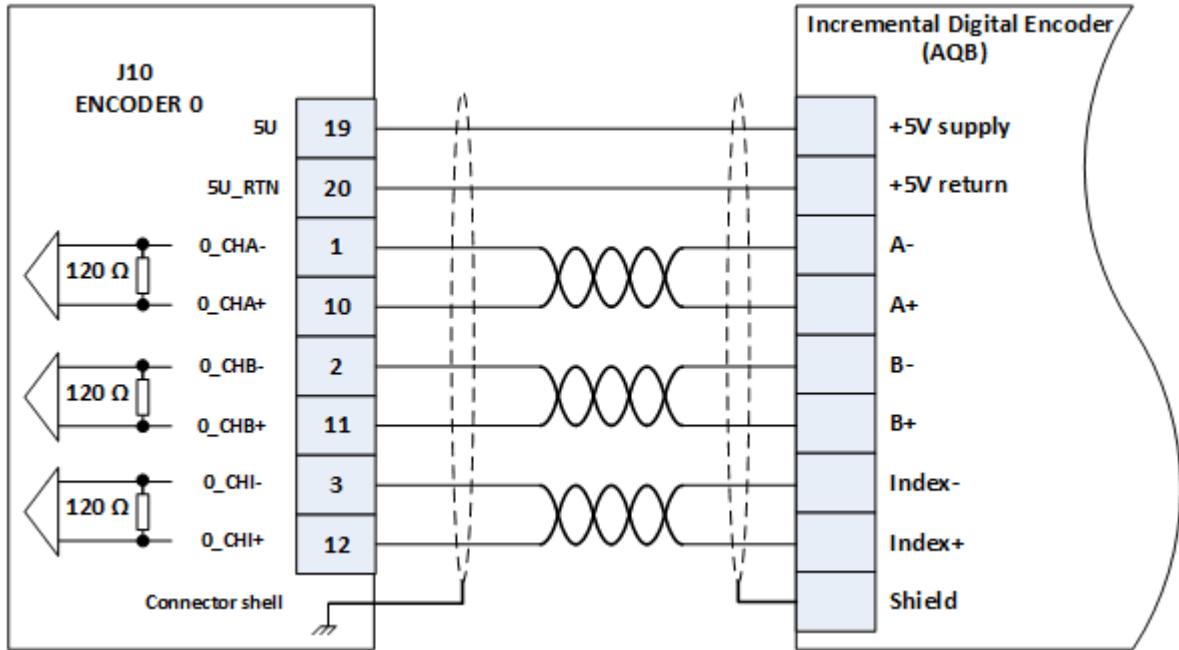

Figure 4-13. Incremental Digital Encoder (AqB) Connection

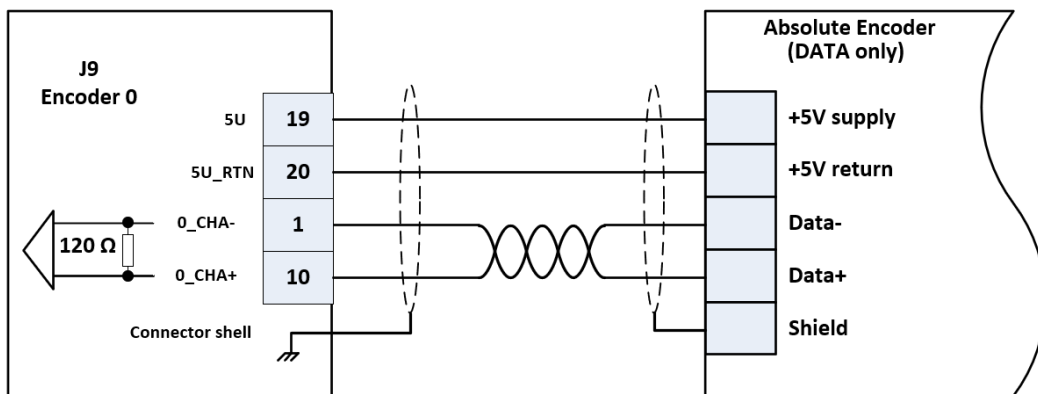

Figure 4-14. Absolute Encoder (Data Only) Connection

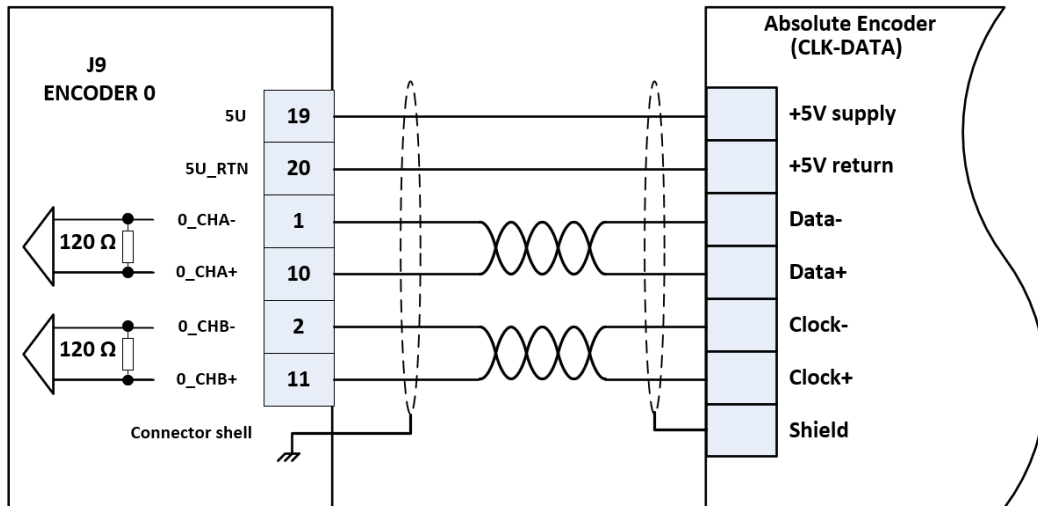

Figure 4-15. Absolute Encoder (CLK-Data) Connection Diagram

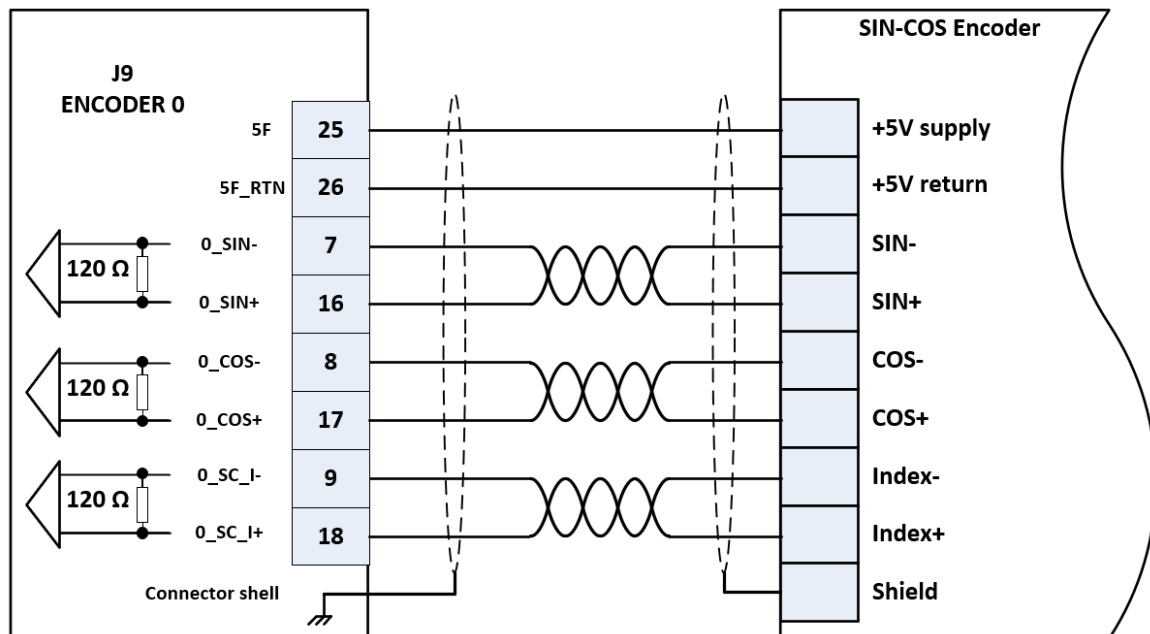

Figure 4-16. SinCos Connection

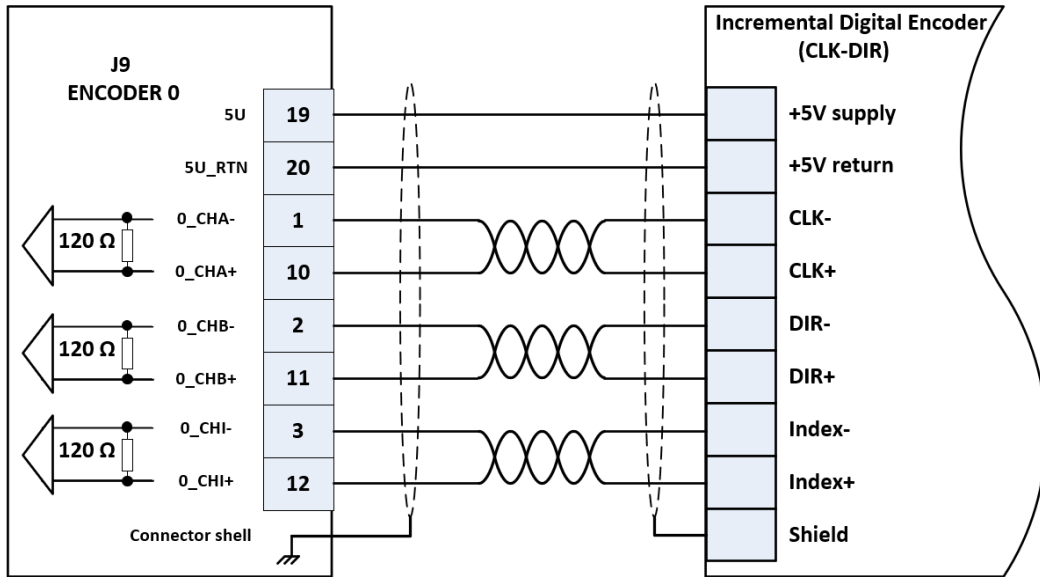

Figure 4-17. Incremental Digital Encoder (CLK-DIR) Connection

4.8.2.1 Additional Device Connections

The system can include an MTMP Motor Temperature sensor, connected according to the following diagram. See [Motor Over Temperature Specifications](#) for more details

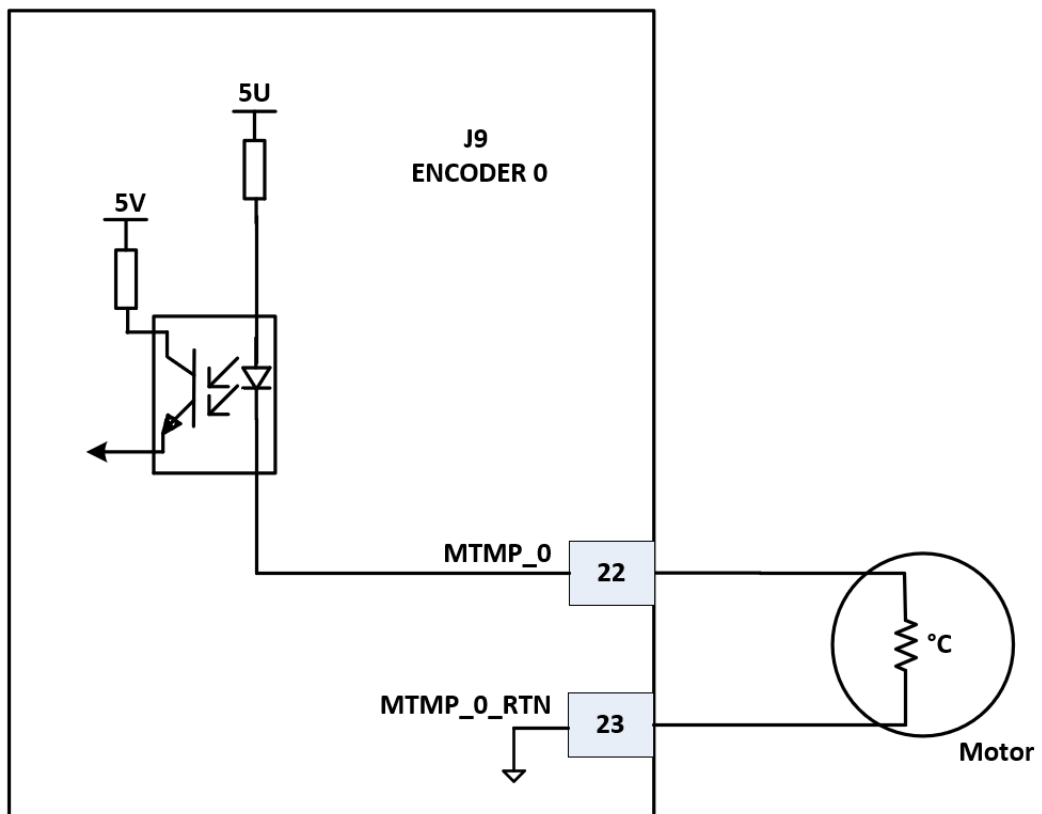

Figure 4-18. MTMP Motor Temperature Sensor Connection

A Hall sensor can also be connected, according to the following diagram.

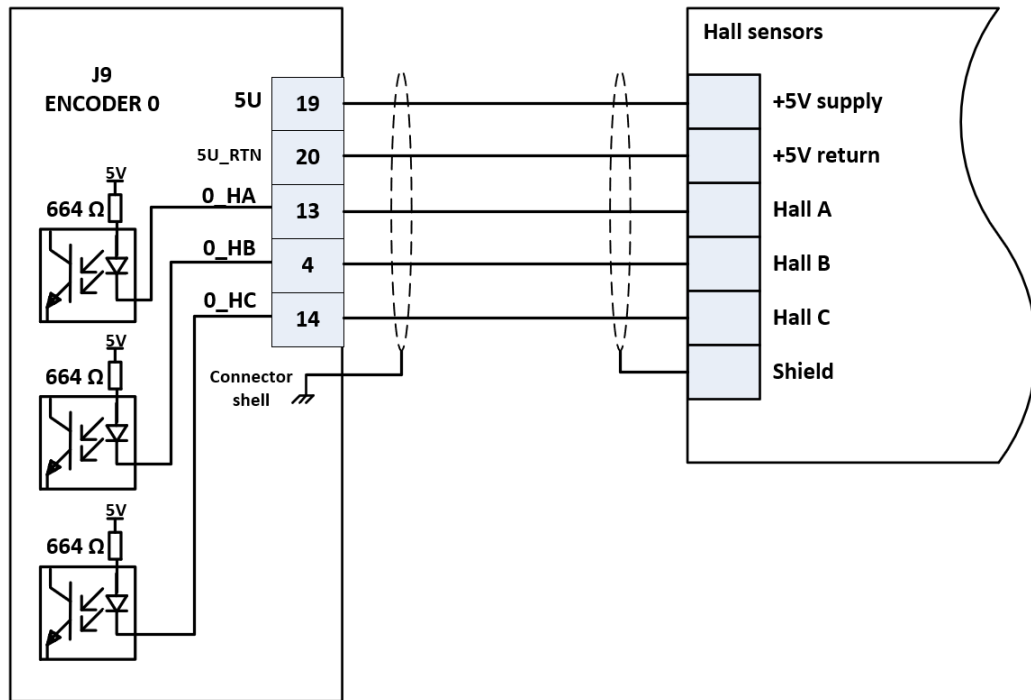

Figure 4-19. Hall Sensor Inputs Connection

4.9 Motors

4.9.1 Motor Description

Connector Name	Motor
Connector Assignment	J12 for MOTOR0
Mating type	Phoenix MSTB 2,5 HC/ 4-STF-5,08

	Name	Description
1	R	Motor Phase R
2	S	Motor Phase S
3	T	Motor Phase T
4	SHIELD	Electrical Ground / Protective Earth

4.9.2 Motor Connection Instructions

1. Use a shielded cable with a minimum gauge of 16 AWG. It should be less than 20 meters long.

2. Route the motor's cable (and the drive supply cable) as far as possible from all other noise sensitive cables (such as encoders and I/O).
3. Connect the motors according to the figures below.

1-Phase Motor Connection

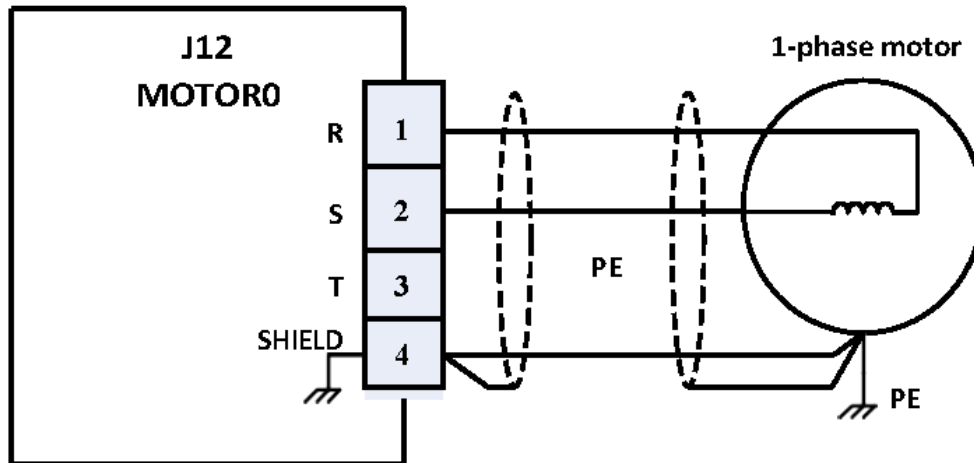

Two-Phase Motor Connection

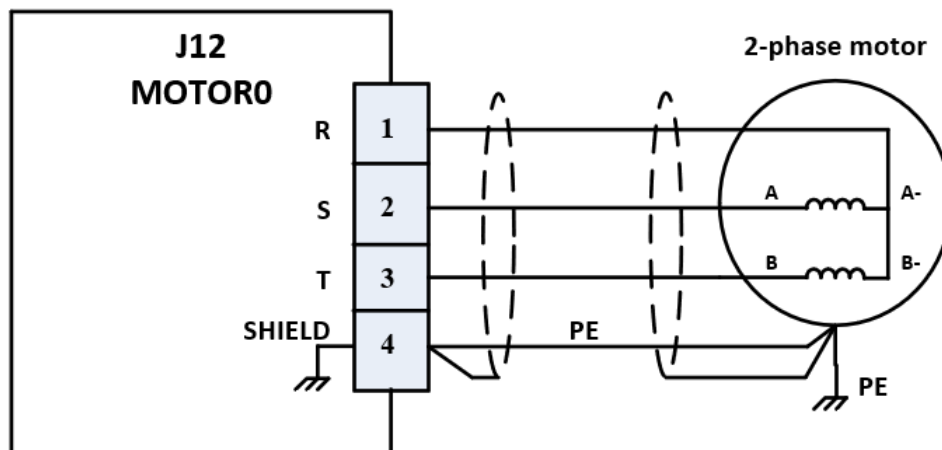

Three-Phase Motor Connection

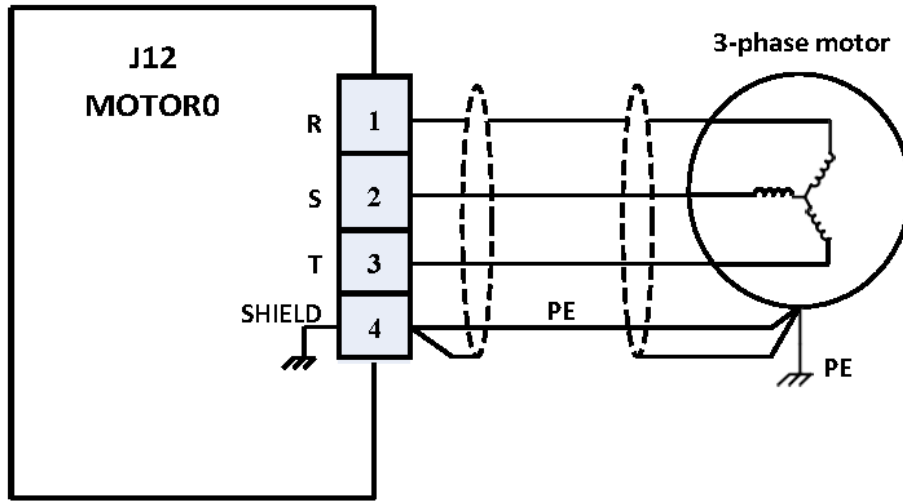

5. Product Specifications

Table 5-1. System Specifications

Feature	Specifications
Drives	<ul style="list-style-type: none"> > Type: PWM three phase power bridge > Output Current (A): <ul style="list-style-type: none"> > For 150V: <ul style="list-style-type: none"> > 2.5/5A continues/Peak sine amplitude or > 5/10A continues/Peak sine amplitude or > 10/20A continues/Peak sine amplitude > For 100V <ul style="list-style-type: none"> > 15/30A continues/Peak sine amplitude Note: the 100V/30A version has a different part number > Maximum output voltage (Vrms): 104V (phase to phase) for 150V 65V (phase to phase) for 100V (92% modulation) > PWM frequency: 20 kHz > Output power per axis (W): <ul style="list-style-type: none"> > 316/629W (continuous/Peak) for 2.5/5A > 633/1258W (continuous/Peak) for 5/10A > 1266/2517W (continuous/Peak) for 10/20A > 1208/2393W (continuous/Peak) for 15/30A > Minimum load inductance at 24VDC: 12.5 μH per phase > Minimum load inductance at 150VDC: 150μH per phase > Commutation type: Sinusoidal. Initiation with and without hall sensors > Current dynamic range: <ul style="list-style-type: none"> > 1000:1 (standard) > Current Loop Resolution: 16-bit > Protection: <ul style="list-style-type: none"> > Short and over current: 40A > Over Temperature: 100°C (on the product's PCB) > Over voltage: <ul style="list-style-type: none"> > 176V±3% for 150V > 120V±3% for 100V > Under voltage: 11V±3%
Supply	<p>The module is fed by two power sources:</p> <ul style="list-style-type: none"> > Drive Supply > 24Vdc control supply. <p>During emergency conditions there is no need to remove the 24Vdc control supply.</p>

Feature	Specifications
Motor Drive Supply	<ul style="list-style-type: none"> > Range: 12Vdc to 150Vdc > Maximum input current (continuous/peak), [Arms] <ul style="list-style-type: none"> > 2/4 for 2.5/5A > 4/8A for 5/10A > 8/16A for 10/20A > 12/24 for 15/30A (for 100V version) > Input power (continuous/peak), [W] <ul style="list-style-type: none"> > 318/633A for 2.5/5A > 636/1267 for 5/10A > 1272/2534 for 10/20A > 1215/2412 for 15/30A (for 100V version) > Inrush current: 100A for 40uS @150Vdc
Control Supply	<ul style="list-style-type: none"> > Range: 24Vdc \pm 5% > Maximum input current: <2A @ 22.8Vdc > Protection: short circuit and reverse polarity
Motor Type	<ul style="list-style-type: none"> > 3 Phase motors > 1 phase motors (DC brush, voice coil) > 2/3 phase step motors
Feedback	<p>Standard</p> <ul style="list-style-type: none"> > Incremental digital encoders (AqB) <p>Optional:</p> <ul style="list-style-type: none"> > Absolute encoders > SIN-COS encoder
Incremental Digital Encoder	<ul style="list-style-type: none"> > Interface: Differential, RS422 (12.5MHz A & B input frequency appropriate to 50 million quadrature counts per second) > Maximum input frequency: 50M counts per second for differential > Protection: Encoder error, encoder not connected > Input termination: 120Ω (on each signal pair) > Encoder supply: 5.0 - 5.25V, 1.5A total for all digital encoders.
Sin-Cos Analog Encoder (optional)	<ul style="list-style-type: none"> > Quantity: 2 > Programmable multiplication factor: 4x65536 > Maximum frequency: 500kHz > Maximum acceleration with sin-cos encoder: 10⁸ sin periods/second² > Format: SIN, COS and Index > Type: <ul style="list-style-type: none"> > Differential input > Input impedance: 120$\Omega$$\pm$10% > Encoder voltage range: 1V-PTP\pm10% > Input voltage range: 1.20V-PTP

Feature	Specifications
	<ul style="list-style-type: none"> > Encoder analog output supply: 5.0-5.25V, 1.5A total for all analog encoders. > ADC resolution: 16-bit > Protection: Encoder error, not connected > Designation: SIN±, COS±, SC_I± > Squared SIN-COS: The squared signals of the SIN-COS are available for all encoders
Absolute Encoder (optional)	<ul style="list-style-type: none"> > Up to two: > Type: <ul style="list-style-type: none"> > Smart-Abs: Tamagawa, based on: SA35-17/33bit-LSP-5V > EnDat2.2, Heidenhain, based on ROQ 437 SERIES > BiSS-C > Panasonic: based on AC Servo Motor MINAS A4 Series > SSI > Sanyo ABS > Hiperface DSL > Maximum input frequency: <ul style="list-style-type: none"> > EnDat: 16MHz > Smart-Abs: 2.5MHz > Biss-C: 10MHz > Panasonic: 2.5MHz > Sanyo: 2.5MHz > Interface : Differential RS485 > Encoder supply: 5.0 - 5.25V, 1.5A total for all digital encoders. > Designation: #_CHA, #_CHB
Digital Hall inputs	<ul style="list-style-type: none"> > Four sets of three inputs > Input current: <7mA > Interfaces: 5V Single-ended, source, opto-isolated (open cathode), reference DGND > Designation: \$_HA, \$_HB, \$_HC
Mechanical Brake & GP Digital output	<ul style="list-style-type: none"> > Quantity: 2, one of which can be a mechanical brake > Interface: 5/24V±20%, opto isolated, sink/source > Reference: V_RTN_IO > Output current: 100mA per output > Output drop: 2.5V@0.1A > Protection: short circuit > Designation: OUT0, OUT1
Limit Switch Inputs	<ul style="list-style-type: none"> > Quantity: 2 > Single-ended, 5/24V±20%,opto isolated, sink/source > Protection: short current > Behavior: No current= limit off. > Designation: #_RL, #_LL

Feature	Specifications
Registration MARK Inputs or GP Digital Inputs	<ul style="list-style-type: none"> > Quantity: 2, one of which may be MARK, 5/24V±20% > Interface: opto-isolated, two terminals > Maximum Encoder Frequency: <12.5MHz > Input propagation delay: <100nS > Position latch: Both raising and falling edge > Maximum Input current: <18mA > Maximum Capture Frequency: 2 kHz > Can be used as general purpose inputs > Designation: MARK0±
PEG (Position Event Generator)	<ul style="list-style-type: none"> > (Position Event Generator): One, P/D output pair, AqB output pair > Differential, RS422 compatible > Pulse width: 40 ns to 671 ms > Maximum rate: 10MHz > Can be used as general purpose output > Allocation: By default, the PEG output pins are mapped to ACSPL+ variables. Other optional selections are SW programmable (see the <i>PEG and MARK Operations & Application Notes</i>). > Designation: PEG0± <div style="border: 1px solid black; border-radius: 10px; padding: 5px; margin-top: 10px;">  <p>PEG does not operate with absolute encoders.</p> </div>
Analog Inputs	<ul style="list-style-type: none"> > ±10V±5% or Single- ended 0-10V±5% > Max. input frequency: 1 KHz > Offset: < 100mV > SNR: >78dB > Designation: AIN_#± > Resolution: 16-bit
Analog Outputs	<ul style="list-style-type: none"> > ±10V, differential, two terminal, 10 bit resolution > Offset: ±50mV > Max. output load: 10kΩ > Noise & Ripple: <25mV > Non-linearity: <5% > Designation: AOUT_#± (# = analog output number 0-)
Ethernet Port	<ul style="list-style-type: none"> > Ethernet port for configuration > Interface: TCP/IP communication > Speed: 100 Mbps > Designation: Transmit: ETH#_TX±, Receive: ETH#_RX± > Default IP Address: 10.0.0.100

Table 5-2. Motor Over Temperature Specifications

Item	Description	Remarks
Designation	Motor over temperature: #_OVER_T	
Quantity	One	
Type	<ul style="list-style-type: none"> > Single-ended, opto-isolated > Reference: DGND 	
Threshold	<ul style="list-style-type: none"> > Over temperature protection is on, when the impedance between \$_Motor_OVER pin to ground is above 1kΩ > Over temperature protection is off, when the impedance between \$_Motor_OVER pin to ground is below 1kΩ 	When this protection is not used, the Motor_OVER pin should be shorted to ground.
Default state	Over temperature off = Low impedance <1kΩ	

Table 5-3. STO and SS1 (Optional)

Item	Description	Remarks
Designation	STO1± STO2±	
Quantity	2 inputs	Switch off all axes simultaneously. One input shuts off the upper part of the motor bridge and the other shuts off the lower part.

Item	Description	Remarks
Interface	> 24V isolated, two terminals for each input	
Input current (per input pin)	> <70mA	
Behavioral	No current=drive off.	

Table 5-4. RS232

Item	Description	Remarks
Interface	Isolated	
Designation	COM1_TX COM1_RX	COM1
Quantity	1	
Speed	Up to 115,200 Baud rate	

Table 5-5. SPI

Item	Description	Remarks
Designation	SPI_MISO± (data master input / slave output) SPI_MOSI± (data master output / slave input) SPI_SS± (chip select) SPI_CLK± (clock)	bi-directional interface supports master or slave mode
Quantity	2	
Interface	Differential RS422	
Speed	4 MHz	
Data word length	8 words of 16 bits	

5.1 EtherCAT Cycle Rate

Table 5-6. CTIME Values for ECMsa

Controller	Number of Internal Axes	Maximum Number of Axes	Default Number of Available ACSPL+ Buffers	Maximum Number of Simultaneously Running		Controller Cycle Time					ServoBoost Supported
				Motors	ACSPL+ Buffers	1 (msec) 2 (msec)	0.50 (msec)*	0.25 (msec)*	0.20 (msec)*	Default Value (msec)	
ECMsm-1xxxx-xxxxx	1	1	6	2	6	√	-	-	-	1	-

5.2 Dimensions

- > Length: 128 mm
- > Depth: 139 mm
- > Height: 55 mm

5.3 Weight

- > <600g

5.4 Compliance with Standards

5.4.1 Environment

The operational temperature range is from 0 to + 50°C.

5.4.2 EMC (Pending)

- > EN61326-3-1 under 2014/30/EU directive (STO)
- > EN61800-3
- > EN61500-5-2

5.4.3 Electrical Safety (Pending)

- > IEC 61800-5-1
- > UL-61800-5-1

5.4.4 Functional Safety

- > IEC 61800-5-2:2016 part 5-2
- > IEC 61508 Part 1-7:2010

Smarter



Motion

www.acsmotioncontrol.com
2018 Summer 1, 2018

5 HaTnufa St.
Yokneam Illit 2066717
Israel
Tel: (+972) (4) 654 6440 Fax: (+972) (4) 654 6443

Contact us: sales@acsmotioncontrol.com | www.acsmotioncontrol.com

