

Parker

Manual No. 102-0988-01

Rev. 5

402/403/404XE Series Product Manual

Effective: June, 2012

Supersedes: May, 2012



Electromechanical Positioning Systems



Important User Information

WARNING

FAILURE OR IMPROPER SELECTION OR IMPROPER USE OF THE PRODUCTS AND/OR SYSTEMS DESCRIBED HEREIN OR RELATED ITEMS CAN CAUSE DEATH, PERSONAL INJURY AND PROPERTY DAMAGE.

This document and other information from Parker Hannifin Corporation, its subsidiaries, and authorized distributors provide product and/or systems options for further investigation by users having technical expertise. It is important that you analyze all aspects of your application and review the information concerning the product or system in the current product catalog. Due to the variety of operating conditions and applications for these product systems, the user, through its own analysis and testing, is solely responsible for making the final selection of the products and systems and assuming that all performance, safety, and warning requirements of the application are met.

The products described herein, including without limitation, product features, specifications, designs, availability and pricing, are subject to change by Parker Hannifin Corporation and its subsidiaries at any time without notice.

The information in the product manual, including any apparatus, methods, techniques, and concepts described herein, are the proprietary property of Parker Hannifin Corporation, Electromechanical Automation-Parker or its licensors, and may not be copied, disclosed, or used for any purpose not expressly authorized by the owner thereof.

Since Parker Hannifin Corporation, Electromechanical Automation-Parker constantly strives to improve all of its products, we reserve the right to change this product manual and equipment mentioned therein at any time without notice.

.....
• *For assistance contact:*
• Parker Hannifin Corporation
• Electromechanical Automation-Daedal
• 1140 Sandy Hill Road
• Irwin, PA 15642
• Phone: 724/861-8200
• 800/245-6903
• Fax: 724/861-3330
• E-mail: ddlcat@parker.com
• Web site: www.parkermotion.com
.....

402/403/404XE Series Product Manual

Table of Contents

IMPORTANT USER INFORMATION	2
REVISION NOTES	4
CHAPTER 1 - INTRODUCTION	5
PRODUCT DESCRIPTION	5
UNPACKING	5
RETURN INFORMATION	6
REPAIR INFORMATION	6
WARNINGS AND PRECAUTIONS	6
SPECIFICATION CONDITIONS	7
ASSEMBLY DIAGRAMS	8
CHAPTER 2 - 402/403/404XE SPECIFICATIONS	10
ORDER NUMBER NOMENCLATURE - 402XE	10
ORDER NUMBER NOMENCLATURE - 403XE	11
ORDER NUMBER NOMENCLATURE - 404XE	12
DIMENSIONAL DRAWINGS - 402XE	14
DIMENSIONAL DRAWINGS - 403XE	16
DIMENSIONAL DRAWINGS - 404XE	18
PERFORMANCE SPECIFICATIONS - 402XE	20
PERFORMANCE SPECIFICATIONS - 403XE	21
PERFORMANCE SPECIFICATIONS - 404XE	22
TEST METHODOLOGY	23
TECHNICAL DATA - 402/403XE	24
TECHNICAL DATA - 404XE	25
CLEAN ROOM PREPARATION	29
CHAPTER 3 - COMPONENT SPECIFICATIONS	30
MOTOR INFORMATION	30
LIMIT/HOME SWITCH INFORMATION - 402/403XE	30
LIMIT/HOME SWITCH INFORMATION - 404XE	31
ENCODER INFORMATION - 404XE	32
BRAKE INFORMATION - 404XE	33
COUPLING INFORMATION	34
CHAPTER 4 - SETUP AND USAGE	35
MOUNTING ORIENTATION	35
MOUNTING SURFACE REQUIREMENTS	35
BASE THROUGH HOLE MOUNTING - 402/403XE	35
TOE CLAMP MOUNTING - 404XE	36
RISER PLATES	36
PAYLOAD MOUNTING	36
INLINE MOTOR MOUNTING	37
PARALLEL MOTOR MOUNTING - 404XE	37
LIMIT/HOME SWITCH ADJUSTMENT - 402/403XE	40
LIMIT/HOME SWITCH ADJUSTMENT - 404XE	40
CHAPTER 5 - MAINTENANCE AND REPAIR	41
LINEAR BEARING & BALLSCREW LUBRICATION - 402/403XE	41
LINEAR BEARING & BALLSCREW LUBRICATION - 404XE	42
BRAKE INSTALLATION - 404XE	43
ROTARY ENCODER INSTALLATION - 404XE	44
APPENDIX A - ACCESSORIES & SPARE PARTS	45
APPENDIX B - INTERNAL PROTECTION	48

Revision Notes

Revision 1
Original Document

Revision 2 - 10/27/2006
Added C5 and M61 Options to Configurable for 402XE, Page 10
Corrected M37 Motor Option Dims for 402XE, Page 15
Corrected Static Permissible Yaw and Static Permissible Roll Spec for 402/403XE, Page 20 & 21
Reformatted Charts for 402/403XE, Page 24
Clarified Lubricant Application for 402/403XE, Page 41
Corrected Part Number for 403XE Riser Plate, Page 46

Rev 3 October 1 2007
Page 31 Sensor Pack Wiring only Ground Wire was Blue Now Black

Rev 4 May 2012
Updated linear encoder information page 32

Rev 5 June 2012
Updated name of Alvania to GADUS S2 V100 2 on page 42.

Chapter 1 - Introduction

Product Description

402XE Positioner

The 402XE is a linear positioning table, targeted for a blend of performance and value, of approximately 2" width which provides travel length up to 220mm. The recirculating linear bearings support up to 90kg normal load. It features a ballscrew drive of either 2mm or 5mm lead, and is available with several motor mount and limit/home switch options.

403XE Positioner

Similar to but larger than the 402XE, the 403XE is a linear positioning table of just under 3" width which provides travel length up to 655mm. The recirculating linear bearings support up to 160kg normal load. It also features a ballscrew drive of either 5mm or 10mm lead, and is available with several motor mount and limit/home switch options.

404XE Positioner

The 404XE is the largest of the XE positioning table line, with a width of approximately 4" and travel length up to 700mm depending on selected carriage size. Size 9 square rail linear bearings support up to 122.6kg normal load. Ballscrew options range from 5mm lead to 20mm lead, and several motor mount and limit/home switch options are available, as well as feedback and brake options.

Unpacking



Unpacking

Carefully remove the positioner from the shipping container and inspect the unit for any evidence of shipping damage. Report any damage immediately to your local authorized distributor. Please save the shipping container for damage inspection or future transportation.

Incorrect handling of the positioner may adversely affect the performance of the unit in its application. Please observe the following guidelines for handling and mounting of your new positioner.

- DO NOT allow the positioner to drop onto the mounting surface. Dropping the positioner can generate impact loads that may result in flat spots on bearing surfaces or misalignment of drive components.
- DO NOT drill holes into the positioner. Drilling holes into the positioner can generate particles and machining forces that may effect the operation of the positioner. Parker will drill holes if necessary; contact your local authorized distributor.
- DO NOT subject the unit to impact loads such as hammering, riveting, etc. Impacts loads generated by hammering or riveting may result in flat spots on bearing surfaces or misalignment of drive components.
- DO NOT lift the positioner by the cables. Lifting positioner by the cables may effect electrical connections. The unit should be lifted by the base structure only.
- DO NOT expose positioner to mist, spray or submersion in liquids.

Return Information

Returns

All returns must reference a "Return Material Authorization" (RMA) number. Please call your local authorized distributor or Parker Customer Service Department at 800-245-6903 to obtain an "RMA" number.

Repair Information

Out-of-Warranty Repair

Our Customer Service Department repairs Out-of-Warranty products. All returns must reference an "RMA" number. Please call your local authorized distributor or Parker Customer Service Department at 800-245-6903 to obtain an "RMA" number. You will be notified of any cost prior to making the repair.

Warnings and Precautions



Hot Surfaces

DO NOT touch rotary motor coils located on the positioner after high duty operation. Motor temperature may approach 60°C.



Electrical Shock

DO NOT take apart or touch any internal components of the positioner while unit is plugged into an electrical outlet. SHUT OFF power before replacing components to avoid electrical shock.



Vertical Operation

Depending on your load and drive screw selection the carriage and load may backdrive in power loss situations potentially causing product damage or personal injury.



Strain Relieve Electrical Components

All electrical components (such as motors and limit/home switches) must be strain relieved. Failure to strain relieve electrical wires or cables may result in component failure and/or personal injury.



General Safety

Sometimes positioning equipment moves without warning. Keep all personnel away from dynamic travel range.

Specification Conditions

Specifications Are Temperature Dependent

Catalog specifications are obtained and measured at 20°C. Specifications at any other temperature may deviate from catalog specifications. Minimum to maximum continuous operating temperature range (with NO guarantee of any specification except motion) of a standard unit before failure is 5°C to 40°C.

Specifications Are Mounting Surface Dependent

Catalog specifications are obtained and measured when the positioner is fully supported, bolted down, and is mounted to a work surface that has a maximum flatness error of 0.013mm/300mm (0.0005"/ft)

Specifications Are Point of Measurement Dependent

Catalog specifications and specifications in this manual are measured from the center of the carriage, 37.5mm above the carriage surface. All measurements taken at any other location may deviate from these values.

Assembly Diagrams

402/403XE

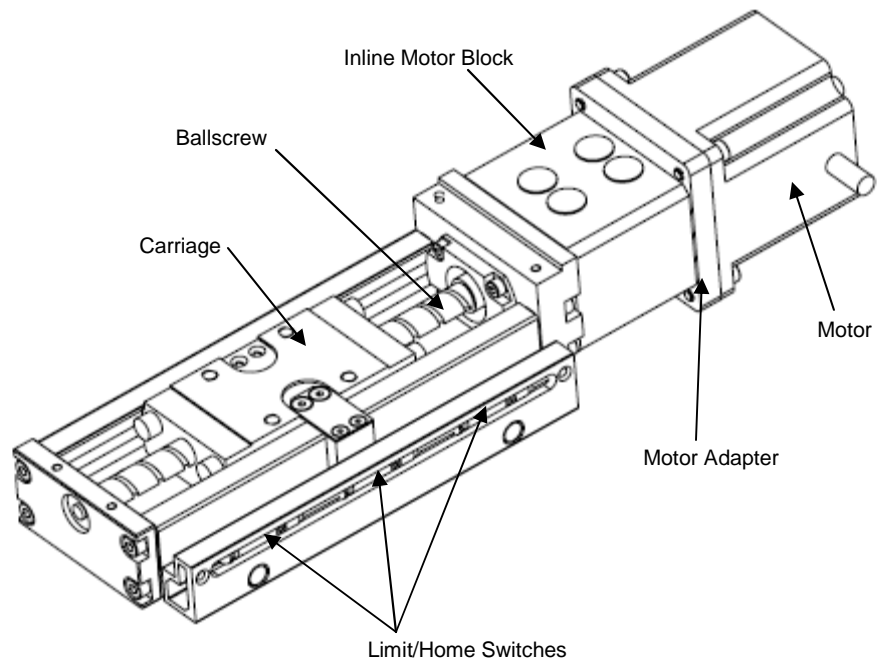
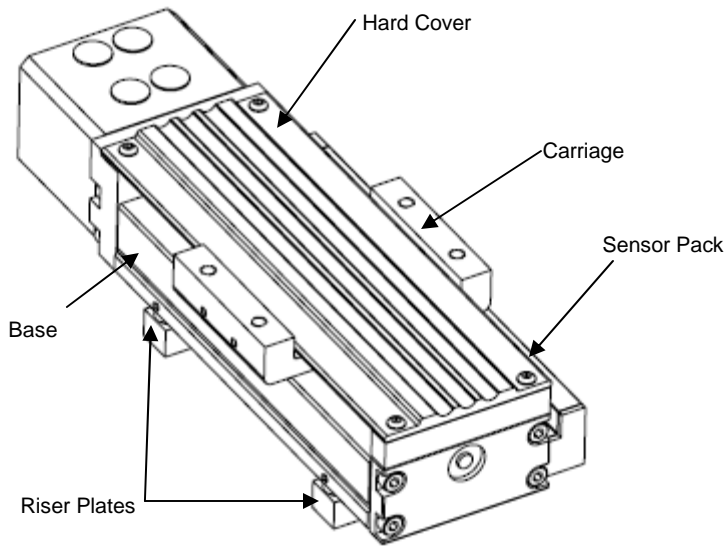

Assembly Diagrams

404XE

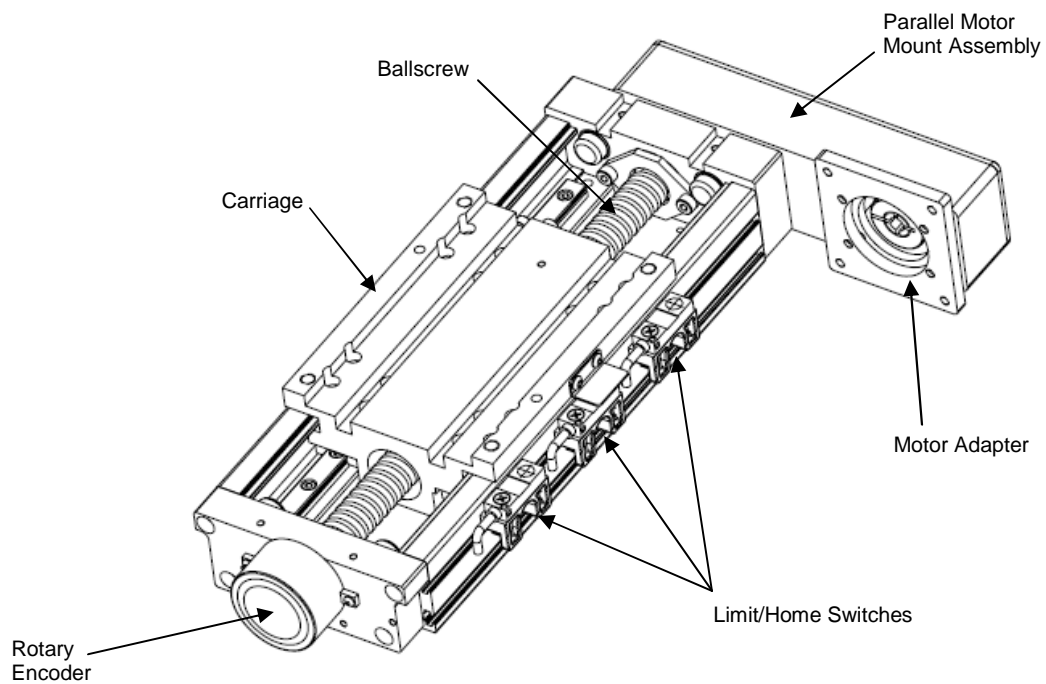
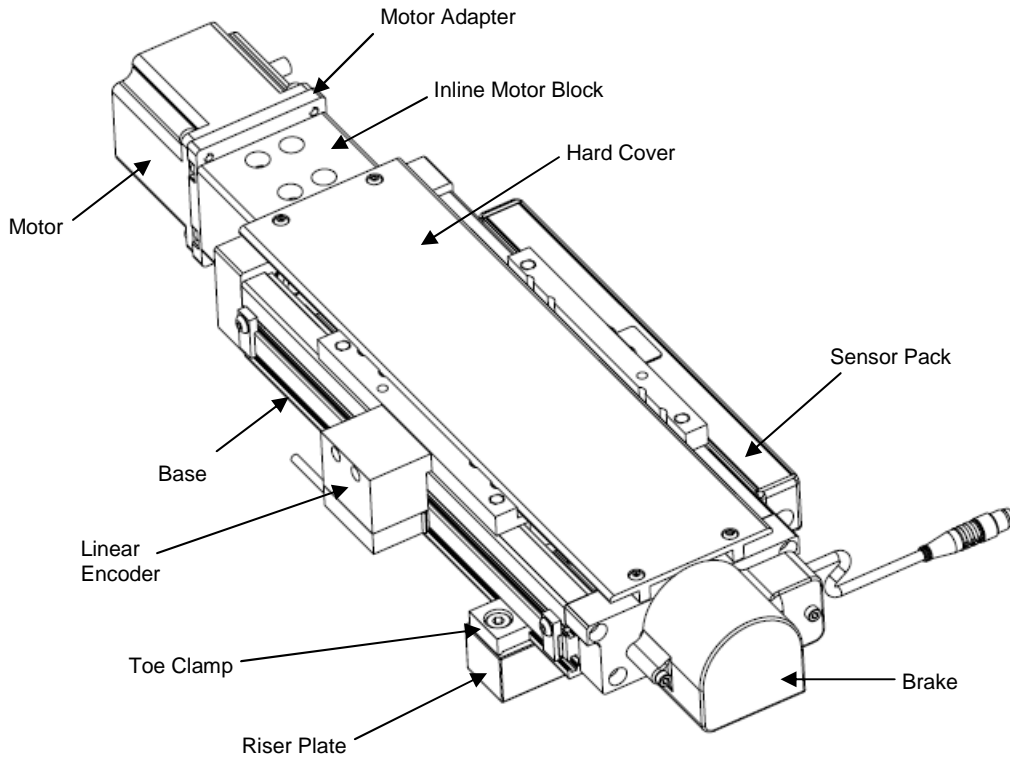

Chapter 2 - 402/403/404XE Specifications

Order Number Nomenclature - 402XE

402XE Series - How to Order

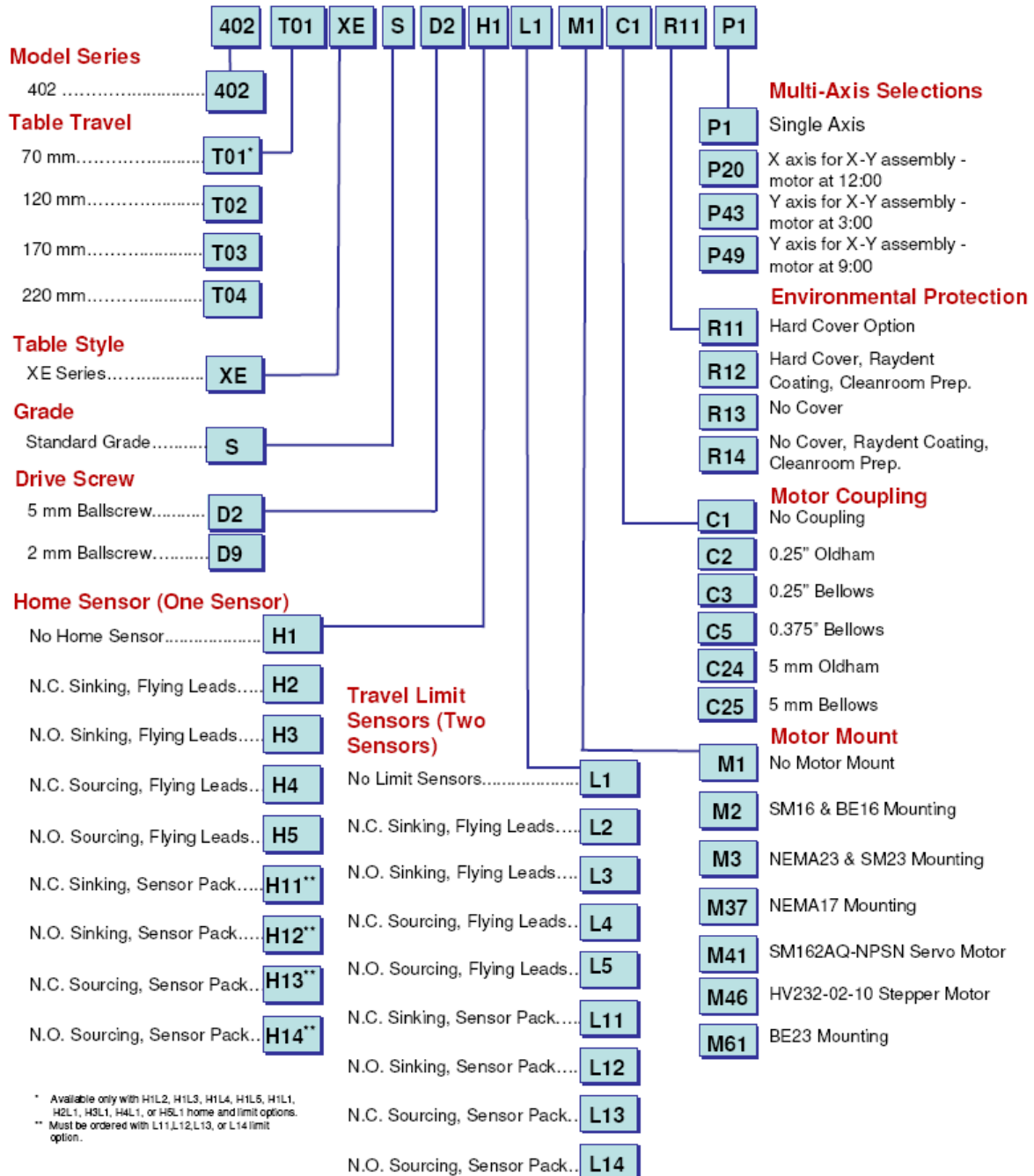

Order Number Nomenclature - 403XE

403XE Series - How to Order

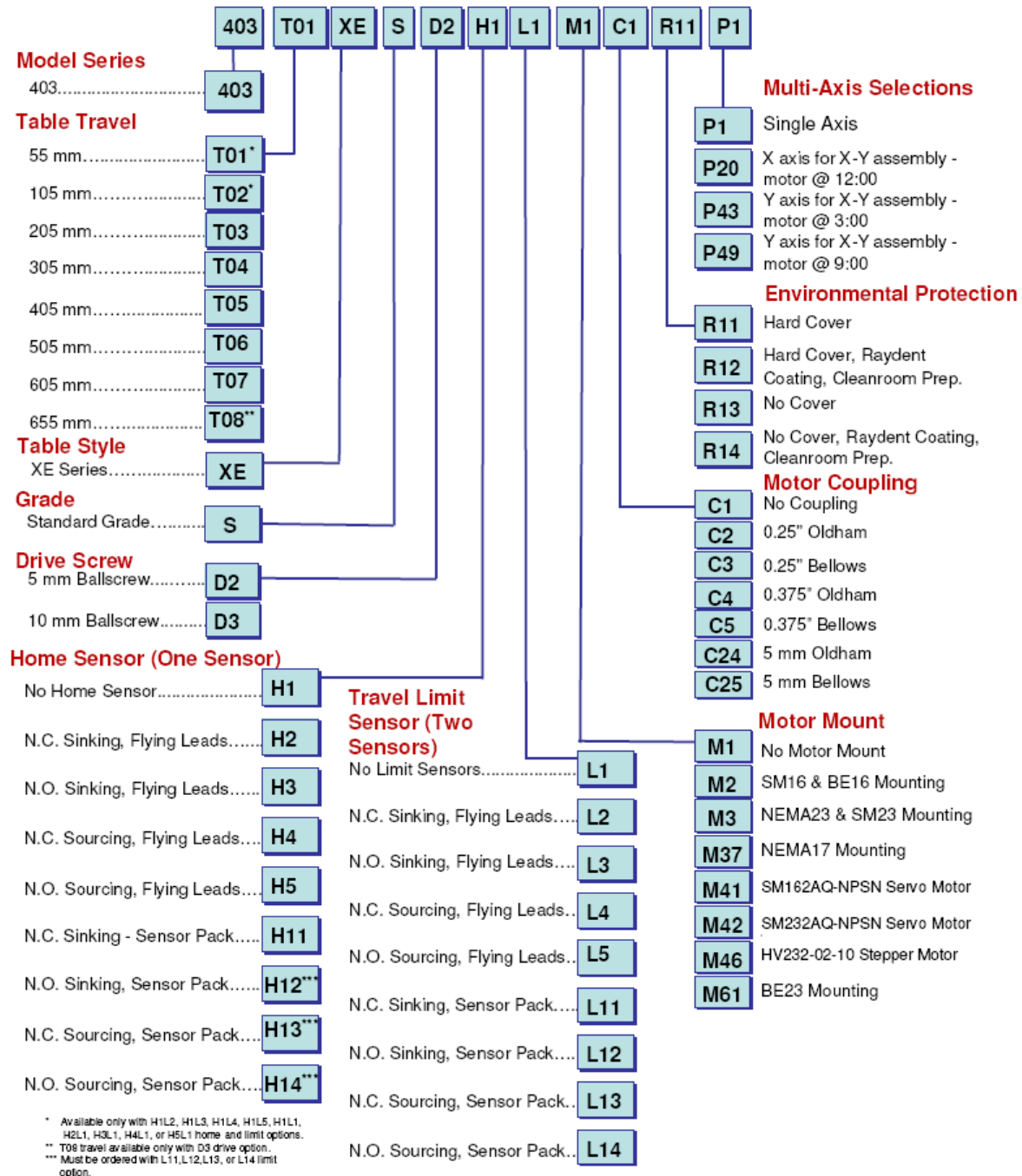

Order Number Nomenclature - 404XE

404XE Series - How to order

Order Example: 404 T08 XE M S - VL D4 H8 L8

Model Series 404

Table Travel (mm)

NL		VL	NL		VL
Short Carriage	Long Carriage		Short Carriage	Long Carriage	
25	n/a	T01*	350	283	T08
50	n/a	T02**	400	333	T09
100	33	T03	450	383	T10
150	83	T04	500	433	T11
200	133	T05	550	483	T12
250	183	T06	600	533	T13
300	233	T07	700	633	T15

* VL carriage, D3 & D4 drives, and Limit/Home Sensor Pack option are not offered with T01 travel models.
 ** VL carriage, D4 drive options are not offered with T02 travel models.

Table Style XE

Mounting (Metric) M

Grade

Standard grade S

Carriage Style

NL - Short NL

VL - Long VL

Drive Screw

Free travel D1

5 mm ballscrew D2

10 mm ballscrew D3*

20 mm ballscrew D4*

* D3 & D4 Drives are not available with T01 travel.
 ** D4 Drives are not available with T02 travels.

Home Sensor Assembly (one sensor)

No home sensor	H1	N.C. current sourcing, w/locking connector	H8
N.C. current sinking, flying leads	H2	N.O. current sourcing, w/locking connector	H9
N.O. current sinking, flying leads	H3	N.C. current sinking-sensor pack	H11
N.C. current sourcing, flying leads	H4	N.O. current sinking-sensor pack	H12
N.O. current sourcing, flying leads	H5	N.C. current sourcing-sensor pack	H13
N.C. current sinking, w/locking connector	H6	N.O. current sourcing-sensor pack	H14
N.O. current sinking, w/locking connector	H7		

Travel Limit Sensor Ass'y. (two sensors)

No limit sensors	L1	N.C. current sourcing, w/locking connector	L8
N.C. current sinking, flying leads	L2	N.O. current sourcing, w/locking connector	L9
N.O. current sinking, flying leads	L3	N.C. current sinking-sensor pack	L11
N.C. current sourcing, flying leads	L4	N.O. current sinking-sensor pack	L12
N.O. current sourcing, flying leads	L5	N.C. current sourcing-sensor pack	L13
N.C. current sinking, w/locking connector	L6	N.O. current sourcing-sensor pack	L14
N.O. current sinking, w/locking connector	L7		

Note: Sensors with locking connector include 5 m extension cable.

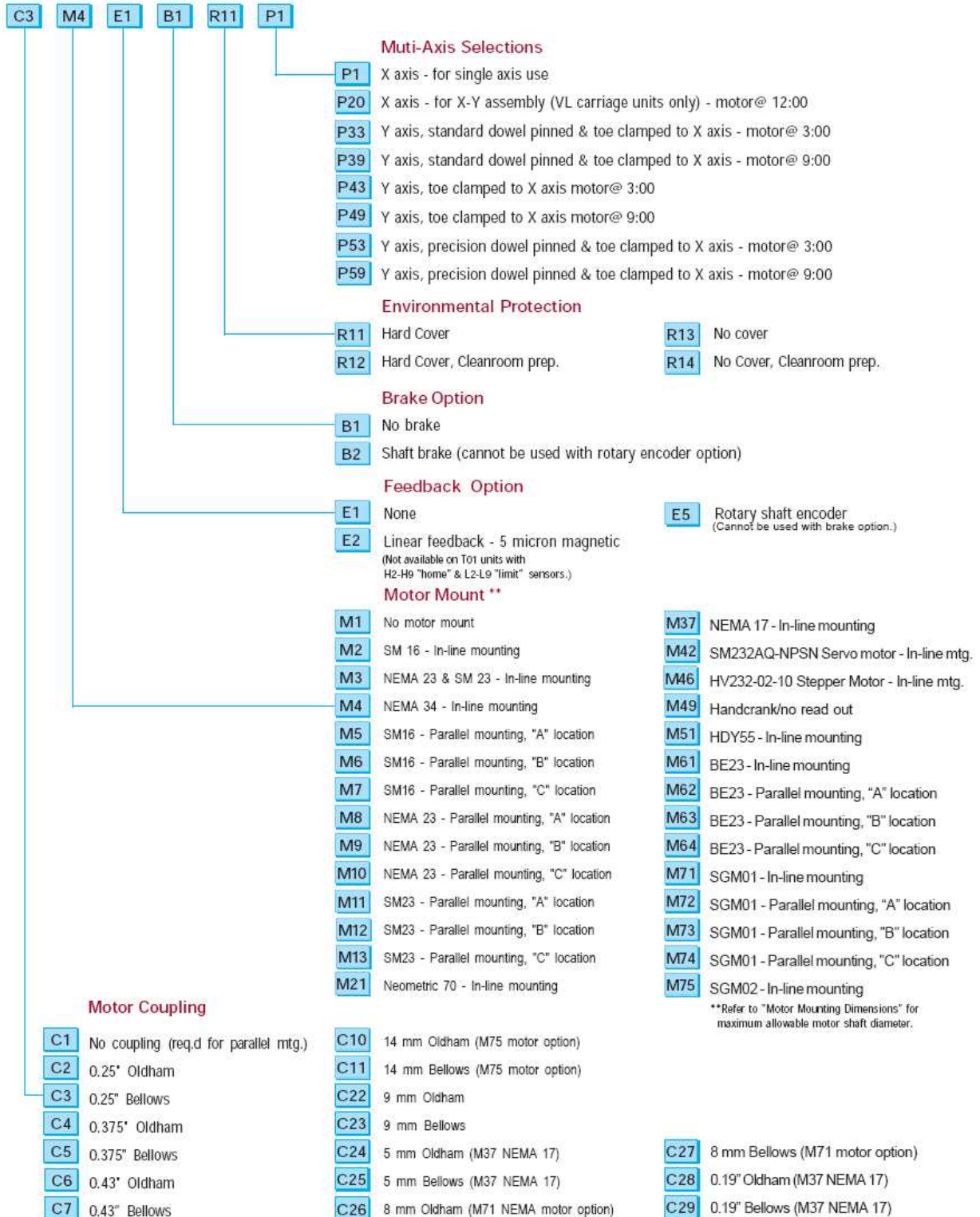

Dimensional Drawings - 402XE

Visit
www.parkermotion.com
 for 2D CAD and 3D Models

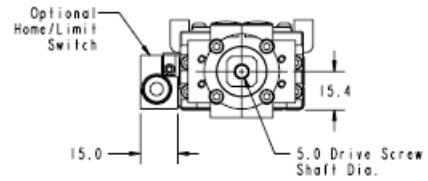
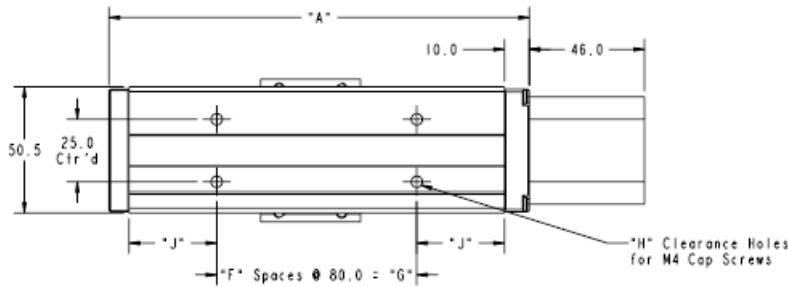
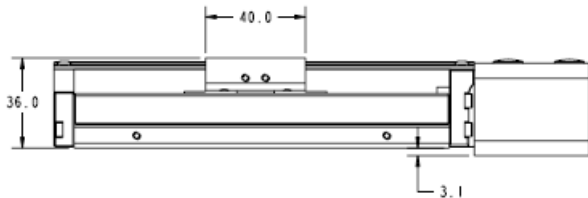
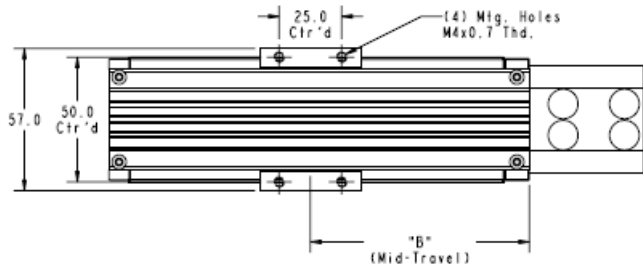

Travel Option	Travel	"A"	"B"	"F"	"G"	"H"	"J"
T01	70 mm	168.0	87.5	1	80.0	4	35.0
T02	120 mm	218.0	112.5	2	160.0	6	20.0
T03	170 mm	268.0	137.5	2	160.0	6	45.0
T04	220 mm	318.0	162.5	3	240.0	8	30.0

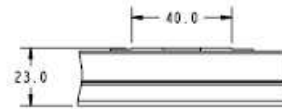
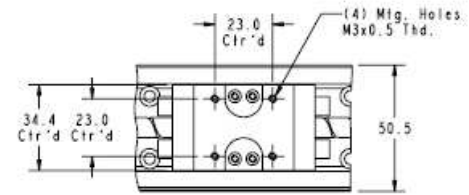

Carriage with No Cover (R13 & R14 Option)

Dimensional Drawings - 402XE

Motor Option	Motor or Motor Size	"L"	"M"	"N"	"R"
M2	SM16/BE16	8.0	40.6	40.6	N/A
M3	NEMA23/SM23	8.0	57.2	57.2	N/A
M37	NEMA17	8.0	43.0	37.0	N/A
M41	SM162AQ-NPSN	8.0	40.6	40.6	136.7
M46	HV232-02-10	8.0	57.2	57.2	71.1
M61	BE23	15.0	57.2	57.2	N/A

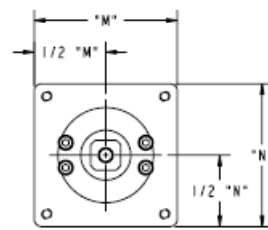
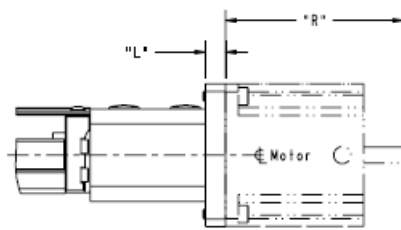

Inline Motor Mount

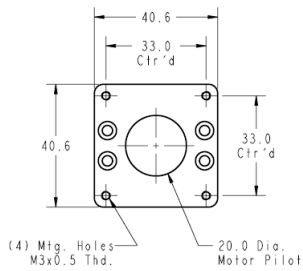

**SM16/BE16 Motor Adapter
Part Number 002-2813-01**

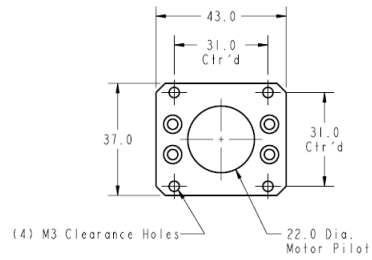

**NEMA17 Motor Adapter
Part Number 002-2814-01**

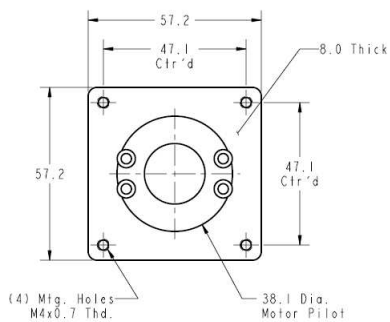

**NEMA23/SM23 Motor Adapter
Part Number 002-2815-01**

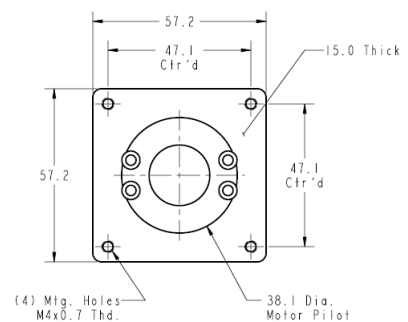

**BE23 Motor Adapter
Part Number 002-2824-01**

Dimensional Drawings - 403XE

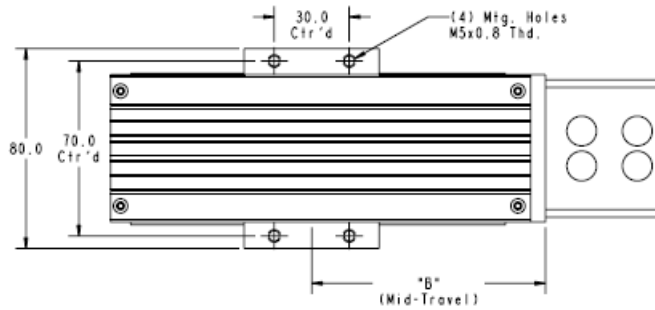

Visit www.parkermotion.com for 2D CAD and 3D Models

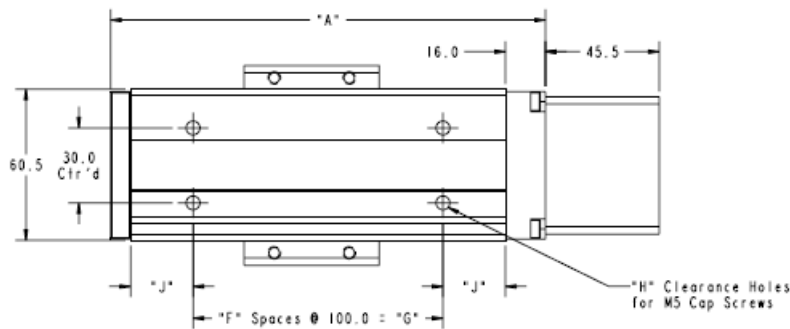
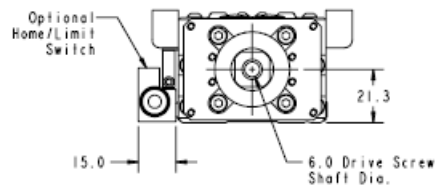

Travel Option	Travel	"A"	"B"	"F"	"G"	"H"	"J"
T01	55 mm	174.0	93.5	1	100.0	4	25.0
T02	105 mm	224.0	118.5	1	100.0	4	50.0
T03	205 mm	324.0	168.5	2	200.0	6	50.0
T04	305 mm	424.0	218.5	3	300.0	8	50.0
T05	405 mm	524.0	268.5	4	400.0	10	50.0
T06	505 mm	624.0	318.5	5	500.0	12	50.0
T07	605 mm	724.0	368.5	6	600.0	14	50.0
T08	655 mm	774.0	393.5	7	700.0	16	25.0

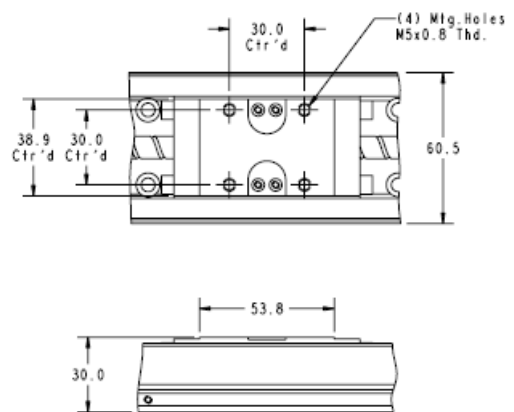

Carriage with No Cover (R13 & R14 Option)

Dimensional Drawings - 403XE

Motor Option	Motor or Motor Size	"L"	"M"	"N"	"R"
M2	SM16/BE16	8.0	40.6	40.6	N/A
M3	NEMA23/SM23	8.0	57.2	57.2	N/A
M37	NEMA17	8.0	55.0	40.6	N/A
M41	SM162AQ-NPSN	8.0	40.6	40.6	136.7
M42	SM232AQ-NPSN	8.0	57.2	57.2	126.5
M46	HV232-02-10	8.0	57.2	57.2	71.1
M61	BE23	15.0	57.2	57.2	N/A

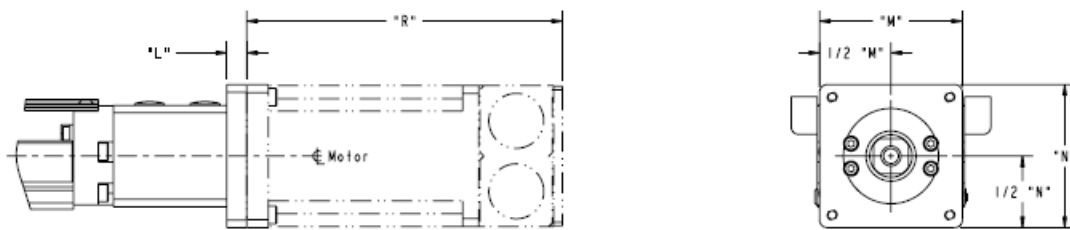

Inline Motor Mount

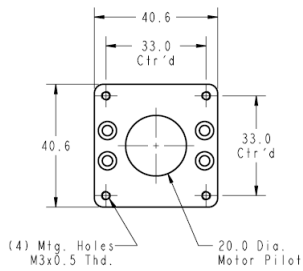

SM16/BE16 Motor Adapter
Part Number 002-2813-01

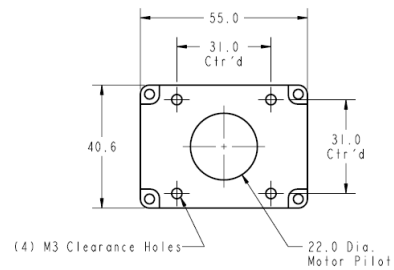

NEMA17 Motor Adapter
Part Number 002-2816-01

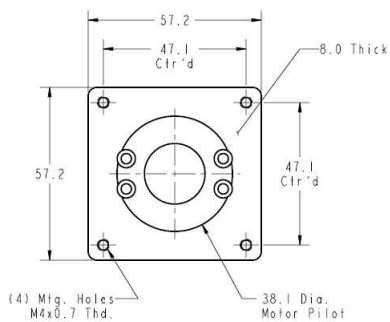

NEMA23/SM23 Motor Adapter
Part Number 002-2815-01

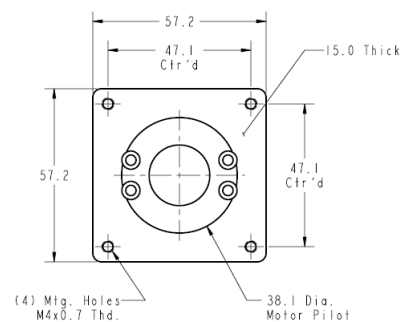

BE23 Motor Adapter
Part Number 002-2824-01

Dimensional Drawings - 404XE

Visit
www.parkermotion.com
 for 2D CAD and 3D Models

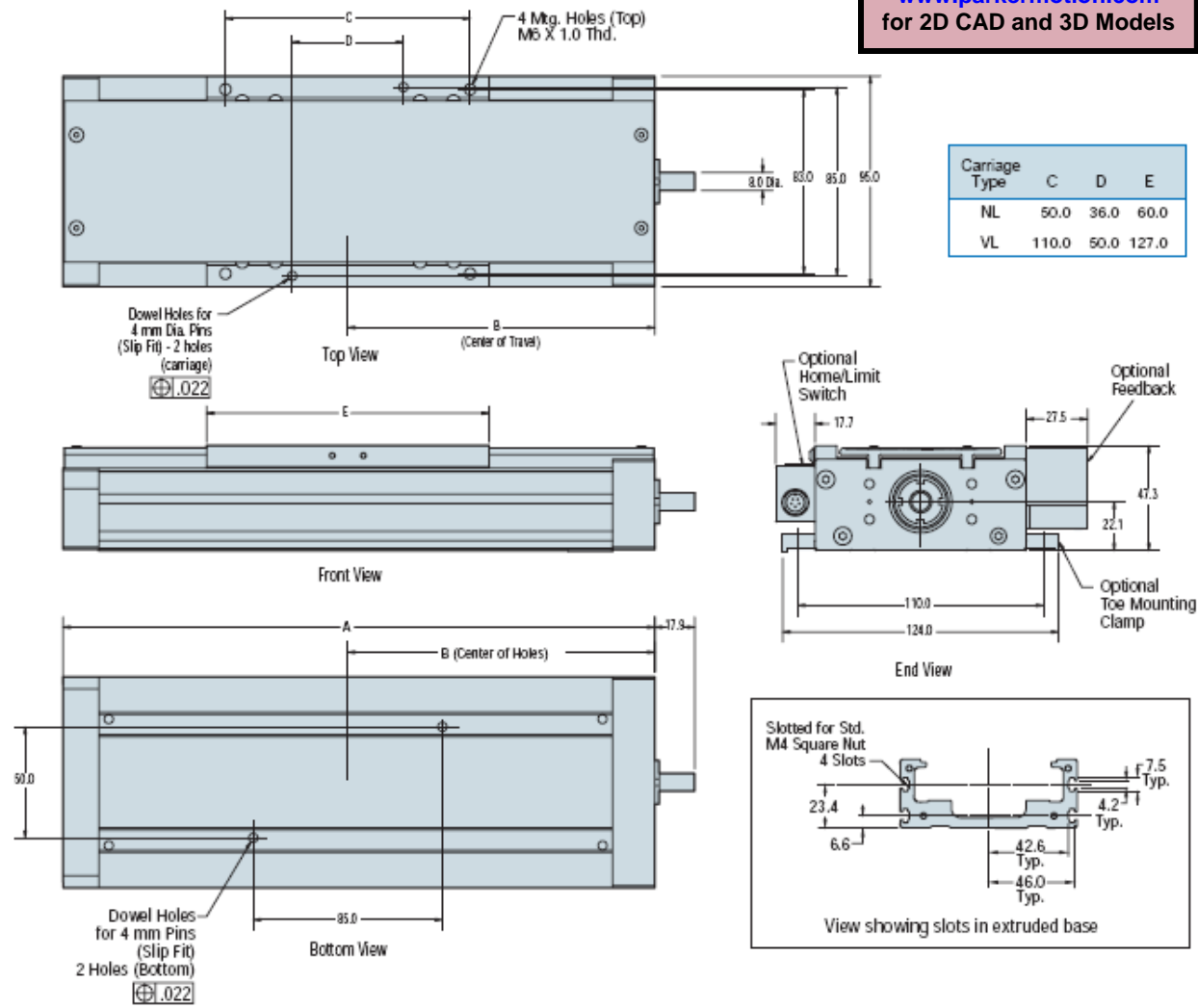

Designation	Carriage Travel		A	B
	NL(short)	VL(long)		
T01	25	N/A	141.0	75.5
T02	50	N/A	166.0	88.0
T03	100	33	216.0	113.0
T04	150	83	266.0	138.0
T05	200	133	316.0	163.0
T06	250	183	366.0	188.0
T07	300	233	416.0	213.0
T08	350	283	466.0	238.0
T09	400	333	516.0	263.0
T10	450	383	566.0	288.0
T11	500	433	616.0	313.0
T12	550	483	666.0	338.0
T13	600	533	716.0	363.0
T15	700	633	816.0	413.0

Dimensional Drawings - 404XE

In-Line Motor Mount

In-line motor mounting allows the motor to be mounted directly to the drive screw via the selected motor coupling.

In-Line Adaptor Plates

Used to easily accommodate the mounting of different frame sizes. These adapter plates can be ordered separately by part number below.

Motor Size	Order Code	Max. Motor Shaft Dia.	K	L	M	N	P
SM16	M2	9.5	41.0	4.3	58.0	45.0	45.0
NEMA 23	M3	9.5	41.0	6.5	58.0	58.0	45.0
NEMA 34	M4	9.5	41.0	12.5	83.0	83.0	45.0
Neometric 70	M21	11.0	53.0	0.0	69.9	69.9	69.9

<p>Part No. 002-3614-01 SM 16</p> <p>In-line SM 16</p>	<p>Part No. 002-3615-01 NEMA 23</p> <p>In-line NEMA 23</p>	<p>Part No. 002-3616-01 NEOMETRIC 70 / SMN060</p> <p>In-line NEOMETRIC 70 /SMN060</p>	<p>Part No. 002-3617-01 NEMA 34</p> <p>In-line NEMA 34</p>
--	--	---	--

Parallel Motor Mounting

Parallel motor mounting is employed whenever a shorter overall unit length is needed. The motor is positioned along the sides or bottom of the table as designated by position A, B, or C. (No coupling required)

Note: Some sensor pack and encoder restriction apply when mounting motors larger than NEMA 23 in the A or B positions. Please consult factory.

Motor Size	Y	Z	Motor Shaft Dia
SM16	45.0	34.5	0.250"
SM23/BE23	58.0	35.5	0.375"
NEMA 23	58.0	35.5	0.250"

Reverse SM 16

Reverse NEMA 23

Performance Specifications - 402XE

402XE Common Performance Characteristics

	2mm Lead (D9 Option)	5mm Lead (D2 Option)
Bidirectional Repeatability - μm	+/- 5	
Duty Cycle	100%	
Max Acceleration - m/s^2 (in/s ²)	20 (787)	
Normal Load Capacity ⁽¹⁾ - kgf (lbs)	90 (198)	
Inverted Load Capacity ⁽¹⁾ - kgf (lbs)	90 (198)	
Axial Load Capacity ⁽¹⁾ - kgf (lbs)	13 (29)	17 (37)
Static Permissible Pitch Moment ⁽¹⁾ - Nm (in-lb)	46 (407)	
Static Permissible Yaw Moment ⁽¹⁾ - Nm (in-lb)	51 (451)	
Static Permissible Roll Moment ⁽¹⁾ - Nm (in-lb)	134 (1186)	
Pitch Torsional Stiffness - Arc Sec/Nm	17.7	
Yaw Torsional Stiffness - Arc Sec/Nm	11.8	
Roll Torsional Stiffness - Arc Sec/Nm	5.9	
Drive Screw Efficiency	90%	
Max Breakaway Torque - Nm (oz-in)	0.06 (8.5)	
Max Running Torque - Nm (oz-in)	0.05 (7.1)	
Linear Bearing Coefficient of Friction	0.01	
Ballscrew Diameter - mm (in)	8.0 (0.32)	
Carriage Weight - kgf (lbs)	0.26 (0.57)	
Moment of Inertia I_x of Positioner Base - mm^4	1.44×10^4	
Moment of Inertia I_y of Positioner Base - mm^4	1.37×10^5	
Enclosure Rating ⁽²⁾	IP20	

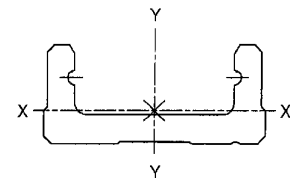

⁽¹⁾ Refer to life/load charts.

⁽²⁾ Applies to units with hard cover (R11 & R12 option).

402XE Travel Dependent Performance Characteristics

Travel Option	Travel	Positional ⁽³⁾ Accuracy - μm	Straightness Accuracy - μm	Flatness Accuracy - μm	Input Inertia - $10^{-6} \text{ kg}\cdot\text{m}^2$		Max Screw Speed - rps	Max Velocity - m/s		Total Table Weight - kgf
					2mm Lead	5mm Lead		2mm Lead	5mm Lead	
T01	70 mm	70	15	15	0.615	0.741	90	0.18	0.45	1.19
T02	120 mm	75	15	15	0.772	0.898	90	0.18	0.45	1.40
T03	170 mm	85	15	15	0.929	1.06	90	0.18	0.45	1.60
T04	220 mm	90	15	15	1.09	1.21	90	0.18	0.45	1.81

⁽³⁾ Positional specifications are based on unloaded conditions and apply to individual axes only.

Performance Specifications - 403XE

403XE Common Performance Characteristics

	5mm Lead (D2 Option)	10mm Lead (D3 Option)
Bidirectional Repeatability - μm	+/- 5	
Duty Cycle	100%	
Max Acceleration - m/s^2 (in/s ²)	20 (787)	
Normal Load Capacity ⁽¹⁾ - kgf (lbs)	160 (353)	
Inverted Load Capacity ⁽¹⁾ - kgf (lbs)	160 (353)	
Axial Load Capacity ⁽¹⁾ - kgf (lbs)	31 (68)	27 (60)
Static Permissible Pitch Moment ⁽¹⁾ - Nm (in-lb)	101 (894)	
Static Permissible Yaw Moment ⁽¹⁾ - Nm (in-lb)	120 (1062)	
Static Permissible Roll Moment ⁽¹⁾ - Nm (in-lb)	260 (2301)	
Pitch Torsional Stiffness - Arc Sec/Nm	9.2	
Yaw Torsional Stiffness - Arc Sec/Nm	6.1	
Roll Torsional Stiffness - Arc Sec/Nm	5.9	
Drive Screw Efficiency	90%	
Max Breakaway Torque - Nm (oz-in)	0.15 (21.2)	
Max Running Torque - Nm (oz-in)	0.10 (14.2)	
Linear Bearing Coefficient of Friction	0.01	
Ballscrew Diameter - mm (in)	10.0 (0.39)	
Carriage Weight - kgf (lbs)	0.40 (0.88)	
Moment of Inertia I_x of Positioner Base - mm^4	3.88×10^4	
Moment of Inertia I_y of Positioner Base - mm^4	3.14×10^5	
Enclosure Rating ⁽²⁾	IP20	

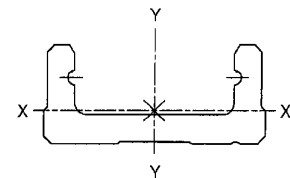

⁽¹⁾ Refer to life/load charts.

⁽²⁾ Applies to units with hard cover (R11 & R12 option).

403XE Travel Dependent Performance Characteristics

Travel Option	Travel	Positional ⁽³⁾ Accuracy - μm	Straightness Accuracy - μm	Flatness Accuracy - μm	Input Inertia - 10^{-6} kg-m ²		Max Screw Speed - rps	Max Velocity - m/s		Total Table Weight - kgf
					5mm Lead	10mm Lead		5mm Lead	10mm Lead	
T01	55 mm	70	15	15	1.72	2.50	80	0.40	0.80	1.85
T02	105 mm	80	15	15	2.10	2.88	80	0.40	0.80	2.25
T03	205 mm	90	15	15	2.87	3.65	80	0.40	0.80	2.85
T04	305 mm	95	15	15	3.63	4.42	80	0.40	0.80	3.55
T05	405 mm	100	25	25	4.40	5.18	80	0.40	0.80	4.25
T06	505 mm	110	25	25	5.17	5.95	80	0.40	0.80	4.85
T07	605 mm	120	25	25	5.93	6.72	60	0.30	0.60	5.55
T08	655 mm	130	25	25	N/A	7.10	42	N/A	0.42	5.85

⁽³⁾ Positional specifications are based on unloaded conditions and apply to individual axes only.

Performance Specifications - 404XE

404XE Common Performance Characteristics

		5mm Lead (D2 Option)	10mm Lead (D3 Option)	20mm Lead (D4 Option)
Bidirectional Repeatability - μm	T01 to T11 Option	+/- 10		
	T12 to T15 Option	+/- 15		
Duty Cycle		100%		
Max Acceleration ⁽¹⁾ - m/s^2 (in/s ²)		20 (787)		
Normal Load Capacity ⁽²⁾ - kgf (lbs)	Short Carriage (NL Option)	61.3 (135)		
	Long Carriage (VL Option)	122.6 (270)		
Axial Load Capacity ⁽¹⁾⁽²⁾ - kgf (lbs)		60 (132)	70 (154)	70 (154)
Drive Screw Efficiency		90%		
Max Breakaway Torque - Nm (oz-in)		0.25 (35)		
Max Running Torque (Rated @ 2rps) - Nm (oz-in)		0.21 (30)		
Linear Bearing Coefficient of Friction		0.01		
Ball screw Diameter - mm (in)		16.0 (0.63)		
Carriage Weight - kgf (lbs)	Short Carriage (NL Option)	0.215 (0.47)		
	Long Carriage (VL Option)	0.495 (1.09)		

⁽¹⁾ Applies to units with long carriage (VL Option).

⁽²⁾ Refer to life/load charts.

404XE Travel Dependent Performance Characteristics

Travel Option	Travel		Positional Accuracy ⁽³⁾⁽⁴⁾ - μm	Input Inertia - 10^{-5} kg-m ²						Max Screw Speed - rps	Max Velocity - m/s			Total Table Weight - kgf	
	NL Option	VL Option		NL Option			VL Option				5mm Lead	10mm Lead	20mm Lead	NL Option	VL Option
				5mm Lead	10mm Lead	20mm Lead	5mm Lead	10mm Lead	20mm Lead						
T01	25 mm	N/A	42	0.81	N/A	N/A	N/A	N/A	N/A	72	0.36	0.73	1.50	1.42	1.70
T02	50 mm	N/A	50	0.94	0.98	N/A	N/A	N/A	N/A	72	0.36	0.73	1.50	1.61	1.89
T03	100 mm	33 mm	58	1.19	1.23	1.12	1.21	1.30	1.40	72	0.36	0.73	1.50	1.95	2.23
T04	150 mm	83 mm	66	1.44	1.48	1.32	1.46	1.55	1.60	72	0.36	0.73	1.50	2.35	2.63
T05	200 mm	133 mm	74	1.69	1.73	1.51	1.71	1.80	1.79	72	0.36	0.73	1.50	2.59	2.87
T06	250 mm	183 mm	82	1.94	1.99	1.70	1.96	2.06	1.99	72	0.36	0.73	1.50	2.97	3.25
T07	300 mm	233 mm	90	2.20	2.24	1.90	2.21	2.31	2.18	72	0.36	0.73	1.50	3.34	3.62
T08	350 mm	283 mm	98	2.45	2.49	2.09	2.47	2.56	2.37	72	0.36	0.73	1.50	3.50	3.78
T09	400 mm	333 mm	106	2.70	2.74	2.29	2.72	2.81	2.57	72	0.36	0.73	1.50	3.83	4.11
T10	450 mm	383 mm	114	2.95	2.99	2.48	2.97	3.07	2.76	72	0.36	0.73	1.50	4.09	4.37
T11	500 mm	433 mm	122	3.21	3.25	2.67	3.22	3.32	2.96	72	0.36	0.73	1.50	4.22	4.50
T12	550 mm	483 mm	130	3.46	3.50	2.87	3.48	3.57	3.15	72	0.36	0.73	1.50	4.55	4.83
T13	600 mm	533 mm	138	3.71	3.75	3.06	3.73	3.82	3.34	69	0.34	0.68	1.32	4.87	5.15
T15	700 mm	633 mm	154	4.21	4.25	3.45	4.23	4.33	3.73	52	0.26	0.52	1.00	5.12	5.40

⁽³⁾ Positional accuracy applies to inline motor configurations only. Contact factory for parallel motor specifications. Positional specifications are based on unloaded conditions and apply to individual axes only.

⁽⁴⁾ Consult factory for specifications with linear feedback.

Test Methodology

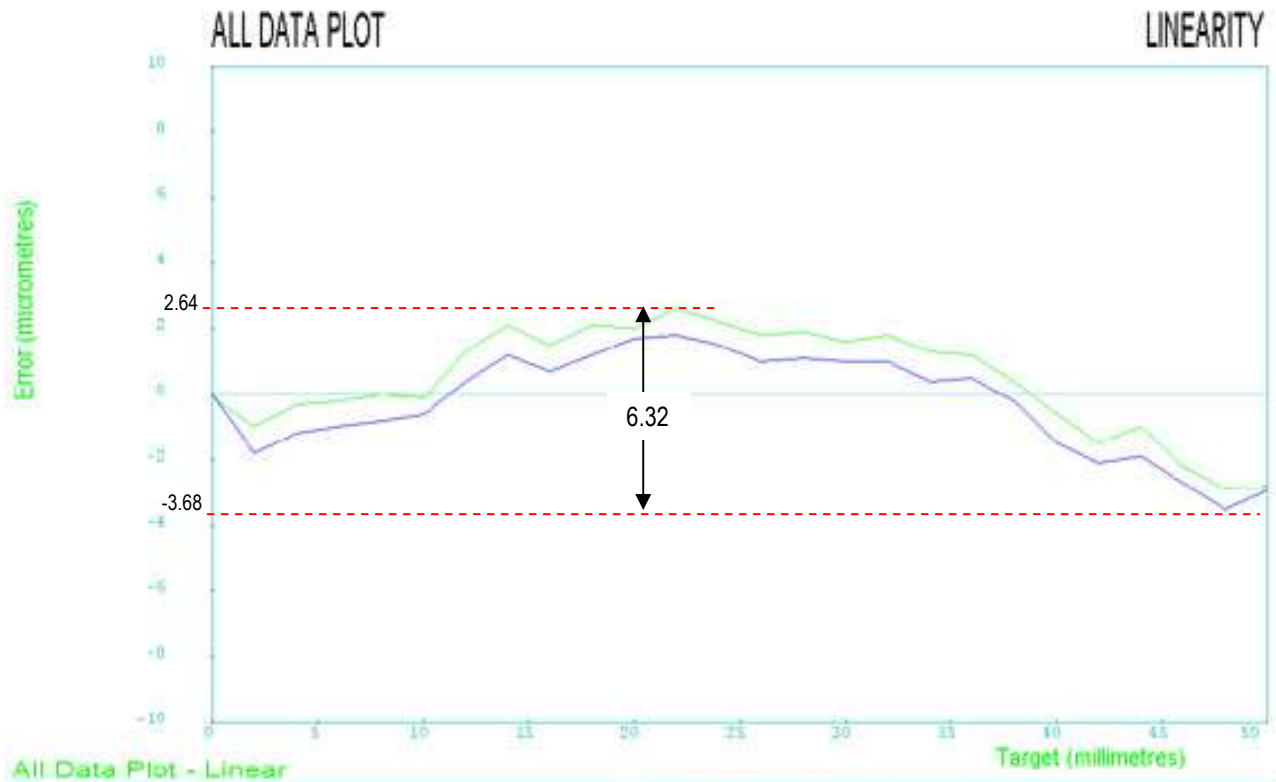

Published accuracy and repeatability specifications are subject to the testing methodology. Parker’s methodology provides specifications over the entire table travel regardless of start or finish position. The accuracy and repeatability specifications are based on the peak to peak error measured by a laser interferometer and prism located at 37.5mm above the center of the table. This type of measurement sums the X, Y, Z, roll, pitch, and yaw errors. Temperature deviations from test condition may cause deviations in straightness, flatness, accuracy, and repeatability from catalog specifications. Tests are performed with the table mounted to a granite table, unloaded at 20° C.

In this example, the accuracy ranges from -3.68 microns to 2.64 microns. This table would have its accuracy specified as 6.32 micron since the worst case would be starting at one extreme and traveling to the other.

Technical Data - 402/403XE

The following performance information is provided as a supplement to the product specifications pages. The useful life of a linear table at full catalog specifications is dependent on the forces acting upon it. These forces include both static components resulting from payload weight, and dynamic components due to acceleration and deceleration of the load. In multi-axis applications, the primary positioner at the bottom of the stack usually establishes the load limits for the combined axes. When evaluating life versus load, it is critical to include the weight of all positioning elements that contribute to the load supported by the primary axis. The following graphs are used to establish the table life relative to the applied loads.

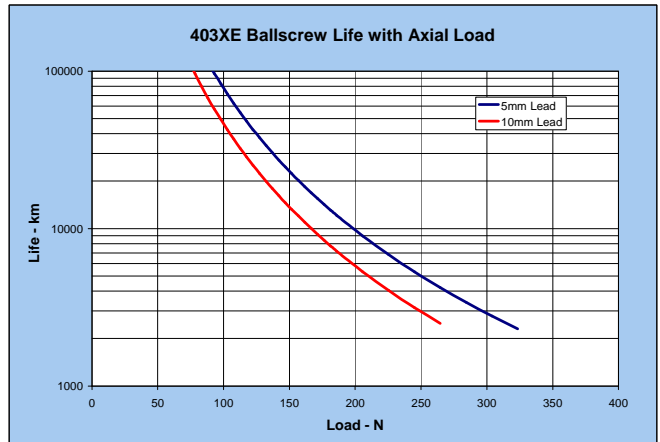
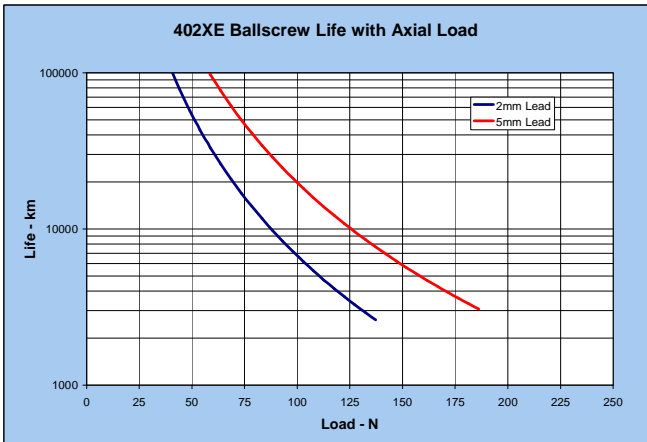
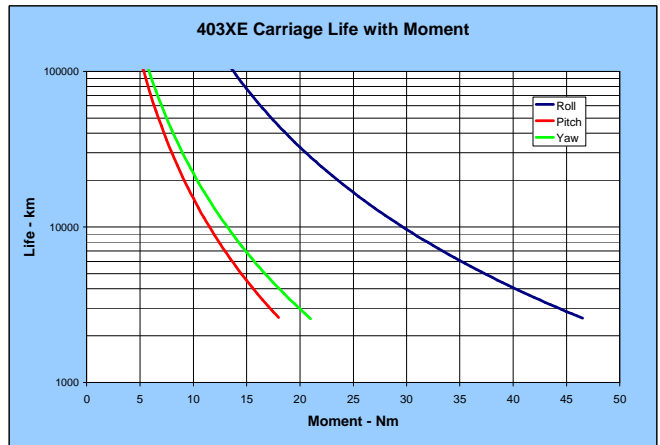
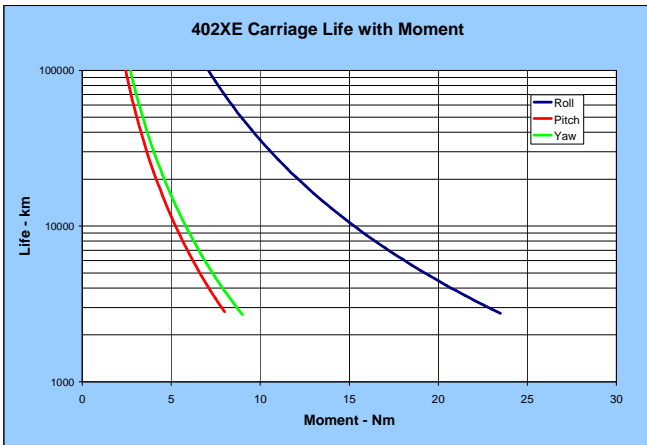
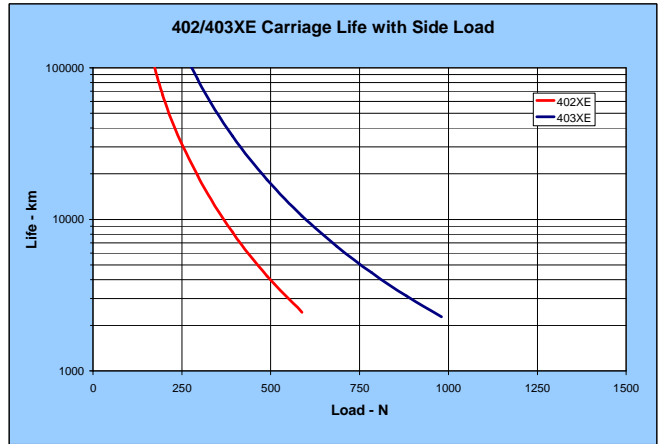
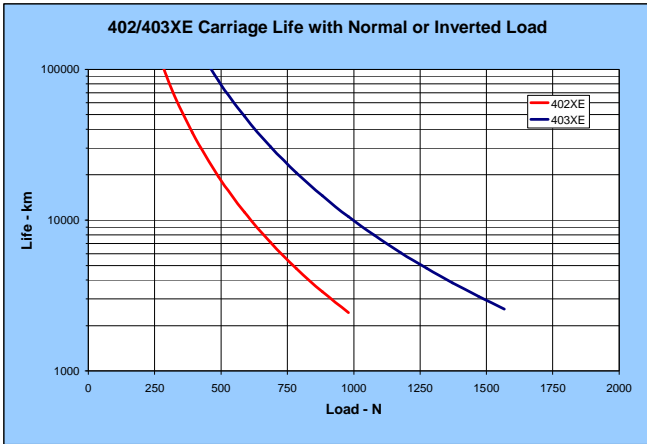

Technical Data - 404XE

The following performance information is provided as a supplement to the product specifications pages. The useful life of a linear table at full catalog specifications is dependent on the forces acting upon it. These forces include both static components resulting from payload weight, and dynamic components due to acceleration and deceleration of the load. In multi-axis applications, the primary positioner at the bottom of the stack usually establishes the load limits for the combined axes. When evaluating life versus load, it is critical to include the weight of all positioning elements that contribute to the load supported by the primary axis. The following graphs and formulas are used to establish the table life relative to the applied loads.

This chart illustrates table ballscrew life relative to axial (thrust) load.

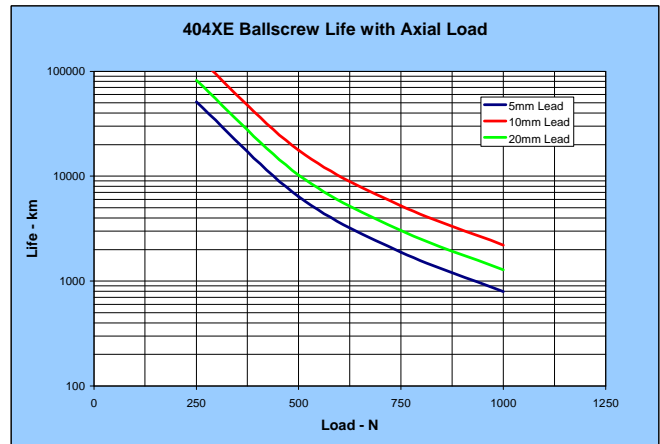

This chart provides an evaluation of the linear support bearing life/load characteristics. The curves show the life/load relationship when the applied load is centered on the carriage, normal (perpendicular) to the carriage mounting surface. For final evaluation of life versus load, including off center, tension, and side loads, refer to the pitch moment chart for the short carriage units or the bearing load charts (next page) for the long carriage units.

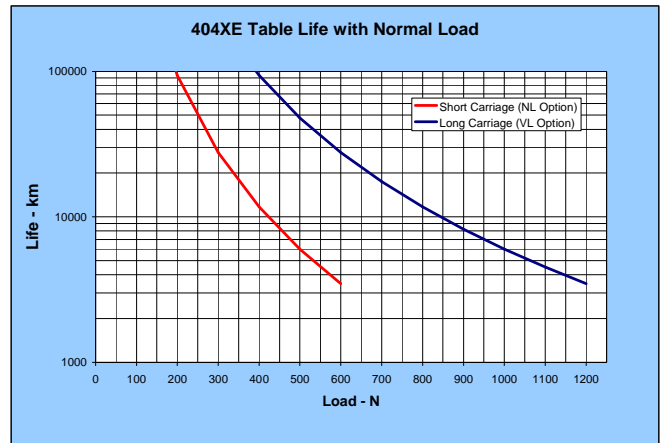

This chart illustrates table linear bearing life relative to pitch moment for the short carriage units.

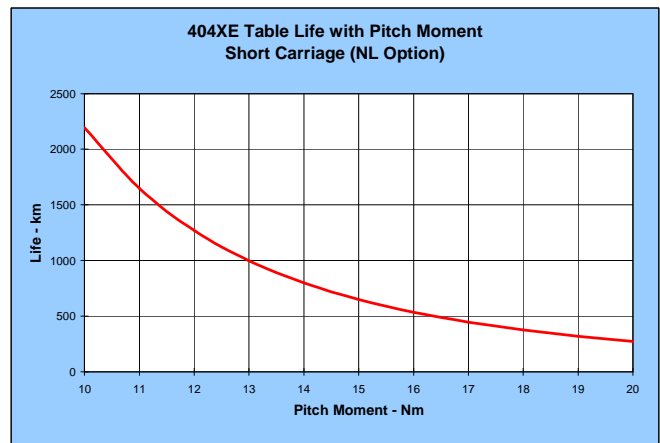

Technical Data - 404XE

These charts are to be used to evaluate long carriage units. They should be used in conjunction with the corresponding formulas on the following pages (also available at www.parkermotion.com) to establish the life relative to load for each bearing (four per table).

Several dimensions, which are specific to each linear positioning table model, and the load geometry are required for these computations. These dimensions are supplied in the catalog information for each positioner. The dimensions are referenced as follows:

- d₁** - Bearing block center-to-center longitudinal spacing
- d₂** - Bearing rail center-to-center lateral spacing
- d_a** - Bearing rail center to carriage mounting surface distance

	d ₁	d ₂	d _a
404XE	80 mm	57 mm	28 mm

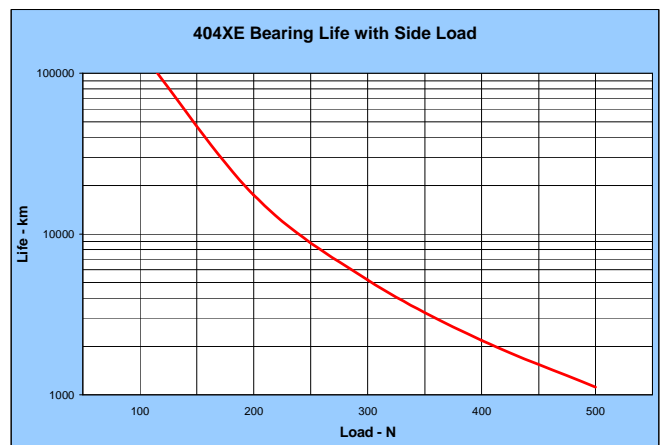
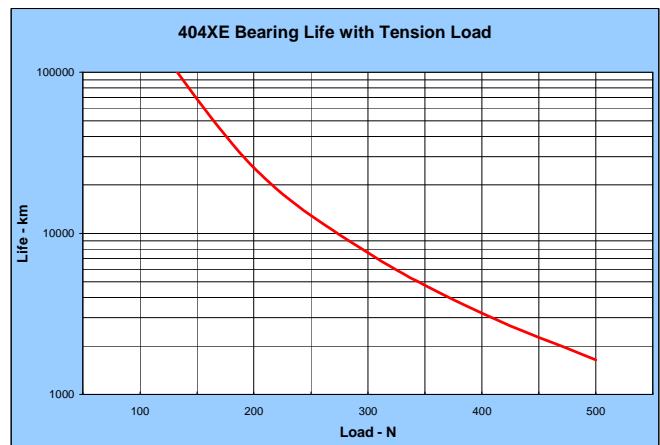
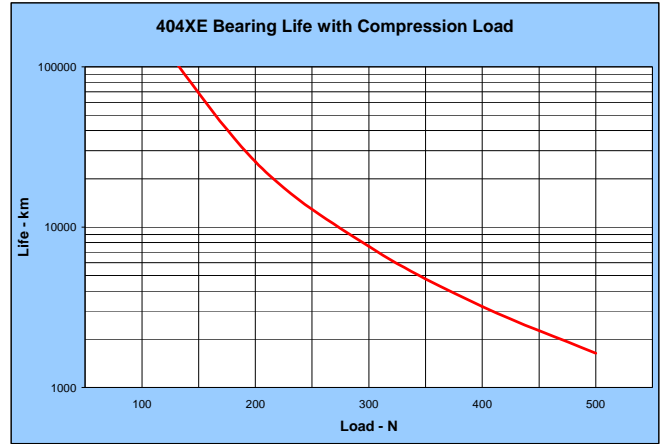

Horizontal Translation — Normal Load

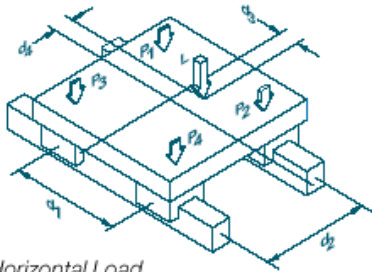

Figure 1: Horizontal Load

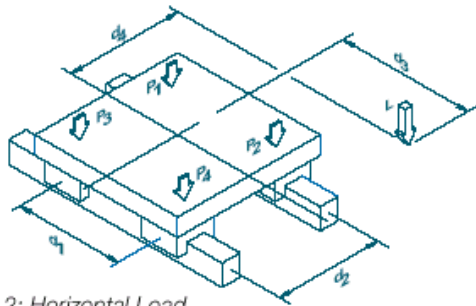

Figure 2: Horizontal Load

$$P_1 = \left[\frac{L}{4} - \left[\frac{L}{2} \cdot \frac{d_3}{d_1} \right] + \left[\frac{L}{2} \cdot \frac{d_4}{d_2} \right] \right]$$

$$P_2 = \left[\frac{L}{4} + \left[\frac{L}{2} \cdot \frac{d_3}{d_1} \right] + \left[\frac{L}{2} \cdot \frac{d_4}{d_2} \right] \right]$$

$$P_3 = \left[\frac{L}{4} - \left[\frac{L}{2} \cdot \frac{d_3}{d_1} \right] - \left[\frac{L}{2} \cdot \frac{d_4}{d_2} \right] \right]$$

$$P_4 = \left[\frac{L}{4} + \left[\frac{L}{2} \cdot \frac{d_3}{d_1} \right] - \left[\frac{L}{2} \cdot \frac{d_4}{d_2} \right] \right]$$

Figure 1 shows a normal load applied to the carriage translating horizontally. The vector L, defined by the CG of the load, is shown applied at a point whose coordinate distances from the center of the carriage are given by dimensions d3 and d4.

With the positioner at rest or moving with uniform velocity, the loads on each of the four bearing blocks are given by the above equations:

Note that each of the four bearing blocks will experience

either compressional or tensional loading; the magnitude of these forces at each bearing is dependent upon the location of the load vector with respect to the center of the positioner carriage. For each bearing, the maximum of the forces in tension and compression is plotted on the load charts for the specific model positioner to determine the life of the table in the application.

The calculations for loads whose CG falls outside the carriage mounting surface area, as shown in Figure 2, are identical to those used with Figure 1. In either case, accelerations and decelerations of the load must be considered in calculating the dynamic forces which determine the life of the system in a particular application.

Horizontal Translation — Side Load

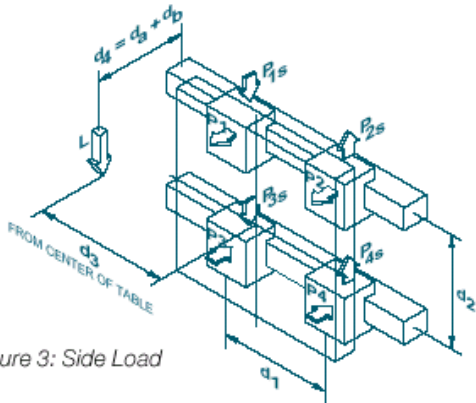

Figure 3: Side Load

The previous loading scenarios have involved only normal forces (compressional or tensional) on the bearings. Consider a positioner as shown in Figure 3, which involves a lateral (side) load applied to the carriage which translates horizontally. The load vector (L) is shown applied at a point whose coordinate distances from the center of the carriage bearing system are given by dimensions d3 and d4. Note that d4 is the sum of distance da—the distance between bearing and center and

carriage surface which is provided for each linear positioner—plus db, the distance of the load CG from the mounting surface of the carriage.

The loading felt by each of the four bearing blocks when the positioner is stationary or moving with uniform velocity is given by the above equations:

Here P1, P2, P3 and P4 are the normal loads (tensional and compression) and P1S, P2S, P3S and P4S are the side loads. For each

$$P_1 = P_2 = \frac{L}{2} \left[\frac{d_4}{d_2} \right]$$

$$P_3 = P_4 = - \frac{L}{2} \left[\frac{d_4}{d_2} \right]$$

$$P_{1s} = P_{3s} = \frac{L}{4} + \left[\frac{L}{2} \cdot \frac{d_3}{d_1} \right]$$

$$P_{2s} = P_{4s} = \frac{L}{4} - \left[\frac{L}{2} \cdot \frac{d_3}{d_1} \right]$$

bearing, the largest side loads and normal loads in both tension and compression are identified for calculating the positioner life in the application.

For round rail/ball bushing type bearings, the forces are plotted individually on the appropriate curves to determine the service life.

For linear motion guide bearing positioners, an “equivalent load per bearing” is calculated for the life determination. Equations listed in Table A, page 22,

apply for the Daedal positioners which incorporate linear motion guide bearings. As shown in Table A, this “equivalent load” is plotted on the indicated load/life graph to determine the positioner’s service life.

Again, accelerations and decelerations of the load must be considered in calculating the dynamic forces which determine the life of the system in a particular application.

Vertical Translation

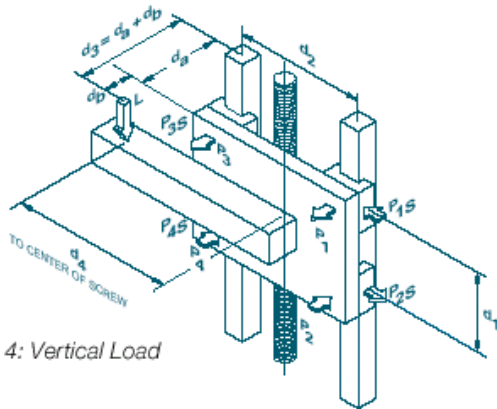

Figure 4: Vertical Load

Figure 4 shows a load applied to the positioner carriage which translates vertically. The load vector (L) is shown applied at a point whose coordinate distances from the center of the carriage bearing system are given by distances d3 and

d4. Note that here d3 is the sum of distance da, which is given for the particular linear positioner plus db, the distance of the load CG from the mounting surface of the carriage. d4 is the horizontal distance of the load vector (L) from the carriage centerline.

$$P_1 = P_3 = \frac{L}{2} \left[\frac{d_3}{d_1} \right]$$

$$P_2 = P_4 = - \frac{L}{2} \left[\frac{d_3}{d_1} \right]$$

$$P_{1s} = P_{3s} = \frac{L}{2} \left[\frac{d_4}{d_2} \right]$$

$$P_{2s} = P_{4s} = - \frac{L}{2} \left[\frac{d_4}{d_2} \right]$$

The loading felt by each of the four bearing blocks when the positioner is stationary or moving with uniform velocity is given by the above equations:

P1 through P4 and P1S through P4S are respectively the normal and side loads on

each bearing block. For each bearing, the largest side loads and normal loads in both tension and compression are determined and, for linear motion guides, "equivalent loads" are computed from the equations in Table A (below) following the same procedure described in the preceding section for *Horizontal Translation with Side Load* to calculate the positioner life in the applications.

Once more, accelerations and decelerations of the load must be considered in calculating the dynamic forces which determine the life of the system in a particular application.

Table A - Linear Motion Guide Bearing Load/Life Computation

Positioner	Loads	Compute*	Evaluate Life On
400XR	Side & tension $P_s > P_t$ Side & tension $P_s \leq P_t$	$P_e = (0.5 * P_t) + P_s$ $P_e = (0.5 * P_s) + P_t$	Side load chart Tension chart
	Side & compression $P_s > P_c$ Side & compression $P_s \leq P_c$	$P_e = (0.5 * P_c) + P_s$ $P_e = (0.5 * P_s) + P_c$	Side load chart Compression chart

Example Computations

Example 1

Horizontal Translation with Side Loads, 404XR Positioner

- L = 20 Kgf
- 50 mm from carriage surface;
- 130 mm from carriage center.

Figure 3 (page 21) shows this configuration with dimensions given here.

- d1 = 80 mm
- db = 50 mm
- d2 = 50 mm
- d3 = 130 mm
- da = 28 mm
- d4 = da + db = 78 mm

The normal and side force components on each bearing block are computed from the equations as shown:

$$P_1 = P_2 = \frac{L}{2} \left[\frac{d_3}{d_1} \right] = 15.7 \text{ (tension) Kgf}$$

$$P_3 = P_4 = - \frac{L}{2} \left[\frac{d_3}{d_1} \right] = -15.7 \text{ (compression) Kgf}$$

$$P_{1s} = P_{3s} = \frac{L}{4} + \left[\frac{L}{2} * \frac{d_4}{d_1} \right] = 21.3 \text{ Kgf}$$

$$P_{2s} = P_{4s} = \frac{L}{4} - \left[\frac{L}{2} * \frac{d_4}{d_1} \right] = -11.3 \text{ Kgf}$$

Life for each bearing needs to be evaluated independently. For bearings with a side load, refer to the combined equivalent loading factors (Table A).

Example:

Bearing 1 has P1=15.7Kgf tension and P1s=21.3Kgf side load
 $P_{1s} > P_t \Rightarrow P_e = (0.5P_t + P_s) = 29.1 \text{ Kgf}$
 Refer to side load chart (page 20)
 Life @ 29.1Kgf-50,000km

Clean Room Preparation

There is no cleanroom “rating” for motion control products, just individual compatibility with class of cleanrooms. The compatibility is also dependent on measurement location. A point directly below a component may have a different particle count than at a side location. Cleanroom class compatibility information for 402/403/404XE tables with cleanroom preparation (R12 & R14 option) is not available at the time of publication of this product manual. Consult factory for details and cleanroom class compatibility expectations for specific applications.

Standard Cleanroom Preparation:

- Stringent cleaning and handling measures
- Cleanroom rated lubricant
- Raydent coating on 402XE and 403XE positioners

Chapter 3 - Component Specifications

Motor Information

The M41, M42, and M46 motor options supply a Parker servo or stepper motor assembled to the positioner. For specifications and setup and connection parameters, refer to the motor user guides available for download from www.parkermotion.com.

Limit/Home Switch Information - 402/403XE

The limit/home switch installed on the 402XE and 403XE is a hall effect sensor tripped by a magnet located in a housing attached to the carriage. On the switch body is an LED to indicate activation. Normally open (N.O.), normally closed (N.C.), current sinking (NPN) and current sourcing (PNP) variations are selectable with the product. Normally open sensors are typically used for home and normally closed are typically used for limits. With a current sinking sensor, the output lead provides a path to ground when activated, and with a current sourcing sensor, the output lead provides a positive (+) voltage potential relative to ground. Refer to your controller's manual for compatibility. Limit/home switch information is below. See Appendix A for switch part numbers.



402/403XE Limit/Home Switch Specifications

	H2 or L2 Option	H3 or L3 Option	H4 or L4 Option	H5 or L5 Option	H11 or L11 Option	H12 or L12 Option	H13 or L13 Option	H14 or L14 Option
Switch Type	N.C.	N.O.	N.C.	N.O.	N.C.	N.O.	N.C.	N.O.
Logic	NPN	NPN	PNP	PNP	NPN	NPN	PNP	PNP
Operating Voltage	10-30 VDC							
Voltage Drop	2.5 VDC Max							
Continuous Current	100 mA							
Repeatability	100 µm Max							
Reverse Polarity Protection	Yes							
Short Circuit Protection	Yes							
Power-Up Pulse Suppression	Yes							
Enclosure Rating	IP67							
Operating Temperature Range	-25°C to +75°C							
Cable Length	3.0 m from Switch				3.0 m from End of Sensor Pack			

402/403XE Limit/Home Switch Wiring Code

Power (+)	Brown
Output Signal	Black
Ground (-)	Blue

402/403XE Sensor Pack Wiring Code

Power (+)	Red
Limit 1 ⁽¹⁾ Output Signal	Blue
Limit 2 ⁽¹⁾ Output Signal	Orange
Home Output Signal	Green
Ground (-)	Blue
Shield (Connect to Earth Ground)	Green w/ Yellow Stripe

⁽¹⁾ Limit 1 is the switch farthest from the connector on the sensor pack housing; Limit 2 is the switch closest to the connector.

Limit/Home Switch Information - 404XE

The limit/home switch installed on the 404XE is a proximity sensor tripped by a flag attached to the carriage. On the switch body is an LED to indicate activation. Normally open (N.O.), normally closed (N.C.), current sinking (NPN) and current sourcing (PNP) variations are selectable with the product. Normally open sensors are typically used for home and normally closed are typically used for limits. With a current sinking sensor, the output lead provides a path to ground when activated, and with a current sourcing sensor, the output lead provides a positive (+) voltage potential relative to ground. Refer to your controller's manual for compatibility. Limit/home switch information is below. See Appendix A for switch part numbers.



404XE Limit/Home Switch Specifications

	H2 or L2 Option	H3 or L3 Option	H4 or L4 Option	H5 or L5 Option	H6 or L6 Option	H7 or L7 Option	H8 or L8 Option	H9 or L9 Option	H11 or L11 Option	H12 or L12 Option	H13 or L13 Option	H14 or L14 Option
Switch Type	N.C.	N.O.	N.C.	N.O.	N.C.	N.O.	N.C.	N.O.	N.C.	N.O.	N.C.	N.O.
Logic	NPN	NPN	PNP	PNP	NPN	NPN	PNP	PNP	NPN	NPN	PNP	PNP
Input Power	5-30 VDC, 20 mA											
Output	100 mA Max											
Repeatability	+/- 10 µm Unidirectional											
Reverse Polarity Protection	No											
Operating Temperature Range	-26°C to +70°C											
Vacuum Rating	1 x 10 ⁻³ Torr											
Cable Length	2.0 m from Switch				5.0 m from Switch ⁽¹⁾				3.0 m from End of Sensor Pack			

⁽¹⁾ Includes locking connector at distance 150 mm from switch.

404XE Limit/Home Switch Wiring Code

Power (+)	Brown
N.O. Output Signal	Black
N.C. Output Signal	White
Ground (-)	Blue

404XE Sensor Pack Wiring Code

Power (+)	Red
Limit 1 ⁽¹⁾ Output Signal	Blue
Limit 2 ⁽¹⁾ Output Signal	Orange
Home Output Signal	Green
Ground (-)	Black
Shield (Connect to Earth Ground)	Green w/ Yellow Stripe

⁽¹⁾ Limit 1 is the switch farthest from the connector on the sensor pack housing; Limit 2 is the switch closest to the connector.



Do Not Reverse Supply Potential

Reversing supply potential of the 404XE limit/home sensor will destroy the sensor.

Encoder Information - 404XE

Standard feedback options for the 404XE include an optical rotary encoder (E5 option) and magnetic linear encoder (E2 option). Encoder information is below. The linear encoder must be installed at the factory. See Chapter 5 for rotary encoder field installation instructions and Appendix A for rotary encoder assembly part number.

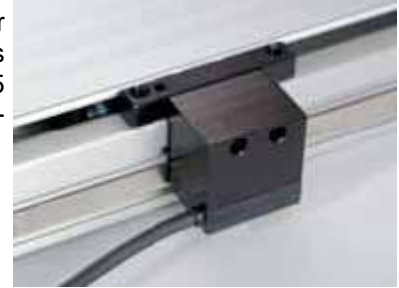

404XE Rotary Encoder Specifications

Input Power	5 VDC, 135 mA
Output	A/B Quadrature and Reference Mark, Differential Line Driver Output
Resolution	1250 Lines/Rev; 5000 Counts Post-Quadrature (1 μ m Resolution When Using a 5mm Lead Ballscrew)
Accuracy	+/- 2 Arc Min
Operating Temperature Range	-10°C to +85°C
Storage Temperature Range	-30°C to +110°C
Cable Length	0.47 m
Cable Material	PVC

404XE Rotary Encoder Wiring Code

Power (+)	Red	Pin 1
Ground (-)	Black	Pin 2
Channel A	White	Pin 3
Channel A /	Yellow	Pin 4
Channel B	Green	Pin 5
Channel B /	Blue	Pin 6
Index	Orange	Pin 7
Index /	Brown	Pin 8
Shield (Connect to Earth Ground)	Bare	None

404XE Linear Encoder Specifications

Input Power	4.7V to 7 V
Output	Square Wave Differential Line Driver Output
Resolution	5 μ m
Accuracy	+/- (0.025 + 0.01 x L) mm, L is length in m
Max Speed ⁽¹⁾	Up to 13.8 m/s
Reverse Polarity Protection	Yes
Operating Temperature Range	-10°C to +80°C
Storage Temperature Range	-40°C to +85°C
Cable Length	5.0 m
Enclosure Rating	IP68 (according to IEC 60529)

404XE Linear Encoder Wiring Code

Power (+)	Brown	PIN 5
Ground (-)	White	PIN 9
Channel A	Green	PIN 4
Channel A /	Yellow	PIN 8
Channel B	Blue	PIN 3
Channel B /	Red	PIN 7
Index	Pink	PIN 2
Index /	Grey	PIN 6
Shield (Connect to Earth Ground)	INNER OUTER	PIN1 CASE

⁽¹⁾ Maximum positioner speed limited by mechanics. See Chapter 2.

Brake Information - 404XE

The brake offered on the 404XE is a rotary type that acts upon the drive screw shaft and is recommended for use in vertical applications. The brake is magnetic engage, electromagnetic release, used to prevent backdriving in a power-loss situation. Brake information is below. See Chapter 5 for field installation instructions and Appendix A for brake assembly part number.



404XE Brake Specifications

Input Power		24 VDC, 0.46 A
Holding Torque		2.0 Nm
Engagement Time (Power Off)		2 ms
Release Time (Power On)		25 ms
Operating Temperature Range		-40°C to +82°C
Cable Length		5.0 m
Wire Color Code	Power (+)	Brown
	Ground (-)	Blue

Coupling Information

Standard coupling offerings include standard grade Oldham style and precision grade bellows style. Coupling information is below. See Appendix A for coupling part numbers.

402XE Coupling Specifications

Coupling Option	Style	Bore Diameter (Motor Shaft) - mm (in)	Outside Diameter - mm (in)	Length - mm (in)	Rated Torque - Nm	Torsional Stiffness - γ Nm	Misalignment			Clamp Screw Torque - in-lb
							Radial	Axial	Angular	
C2	Oldham	6.3 (0.25)	19.1 (0.75)	25.4 (1.00)	2.25	0.380	+/-0.20 mm	+/-0.10 mm	+/-0.5°	11
C3	Bellows	6.3 (0.25)	20.0 (0.79)	26.0 (1.02)	1.50	0.076	+/-0.10 mm	+/-0.25 mm	+/-1.2°	9
C5	Bellows	9.5 (0.38)	20.0 (0.79)	26.0 (1.02)	1.50	0.076	+/-0.10 mm	+/-0.25 mm	+/-1.2°	9
C24	Oldham	5.0 (0.20)	19.1 (0.75)	25.4 (1.00)	2.25	0.380	+/-0.20 mm	+/-0.10 mm	+/-0.5°	11
C25	Bellows	5.0 (0.20)	20.0 (0.79)	26.0 (1.02)	1.50	0.076	+/-0.10 mm	+/-0.25 mm	+/-1.2°	9

403XE Coupling Specifications

Coupling Option	Style	Bore Diameter (Motor Shaft) - mm (in)	Outside Diameter - mm (in)	Length - mm (in)	Rated Torque - Nm	Torsional Stiffness - γ Nm	Misalignment			Clamp Screw Torque - in-lb
							Radial	Axial	Angular	
C2	Oldham	6.3 (0.25)	25.4 (1.00)	31.8 (1.25)	4.75	0.291	+/-0.20 mm	+/-0.10 mm	+/-0.5°	19
C3	Bellows	6.3 (0.25)	20.0 (0.79)	26.0 (1.02)	1.50	0.076	+/-0.10 mm	+/-0.25 mm	+/-1.2°	9
C4	Oldham	9.5 (0.38)	25.4 (1.00)	31.8 (1.25)	4.75	0.291	+/-0.20 mm	+/-0.10 mm	+/-0.5°	19
C5	Bellows	9.5 (0.38)	20.0 (0.79)	26.0 (1.02)	1.50	0.076	+/-0.10 mm	+/-0.25 mm	+/-1.2°	9
C24	Oldham	5.0 (0.20)	19.1 (0.75)	25.4 (1.00)	2.25	0.380	+/-0.20 mm	+/-0.10 mm	+/-0.5°	11
C25	Bellows	5.0 (0.20)	20.0 (0.79)	26.0 (1.02)	1.50	0.076	+/-0.10 mm	+/-0.25 mm	+/-1.2°	9

404XE Coupling Specifications

Coupling Option	Style	Bore Diameter (Motor Shaft) - mm (in)	Outside Diameter - mm (in)	Length - mm (in)	Rated Torque - Nm	Torsional Stiffness - γ Nm	Misalignment			Clamp Screw Torque - in-lb
							Radial	Axial	Angular	
C2	Oldham	6.3 (0.25)	25.4 (1.00)	31.8 (1.25)	4.75	0.291	+/-0.20 mm	+/-0.10 mm	+/-0.5°	19
C3	Bellows	6.3 (0.25)	20.0 (0.79)	26.0 (1.02)	1.50	0.076	+/-0.10 mm	+/-0.25 mm	+/-1.2°	9
C4	Oldham	9.5 (0.38)	25.4 (1.00)	31.8 (1.25)	4.75	0.291	+/-0.20 mm	+/-0.10 mm	+/-0.5°	19
C5	Bellows	9.5 (0.38)	25.0 (0.98)	32.0 (1.26)	2.00	0.038	+/-0.10 mm	+/-0.30 mm	+/-1.2°	11
C6	Oldham	11.0 (0.43)	33.3 (1.31)	47.6 (1.88)	8.00	0.079	+/-0.20 mm	+/-0.15 mm	+/-0.5°	19
C7	Bellows	11.0 (0.43)	32.5 (1.28)	41.5 (1.63)	4.50	0.009	+/-0.10 mm	+/-0.30 mm	+/-1.2°	30
C10	Oldham	14.0 (0.55)	33.3 (1.31)	47.6 (1.88)	8.00	0.079	+/-0.20 mm	+/-0.15 mm	+/-0.5°	19
C11	Bellows	14.0 (0.55)	32.5 (1.28)	41.5 (1.63)	4.50	0.009	+/-0.10 mm	+/-0.30 mm	+/-1.2°	30
C22	Oldham	9.0 (0.35)	25.4 (1.00)	31.8 (1.25)	4.75	0.291	+/-0.20 mm	+/-0.10 mm	+/-0.5°	19
C23	Bellows	9.0 (0.35)	25.0 (0.98)	32.0 (1.26)	2.00	0.038	+/-0.10 mm	+/-0.30 mm	+/-1.2°	11
C24	Oldham	5.0 (0.20)	19.1 (0.75)	25.4 (1.00)	2.25	0.380	+/-0.20 mm	+/-0.10 mm	+/-0.5°	11
C25	Bellows	5.0 (0.20)	20.0 (0.79)	26.0 (1.02)	1.50	0.076	+/-0.10 mm	+/-0.25 mm	+/-1.2°	9
C26	Oldham	8.0 (0.31)	25.4 (1.00)	31.8 (1.25)	4.75	0.291	+/-0.20 mm	+/-0.10 mm	+/-0.5°	19
C27	Bellows	8.0 (0.31)	25.0 (0.98)	32.0 (1.26)	2.00	0.038	+/-0.10 mm	+/-0.30 mm	+/-1.2°	11

Chapter 4 - Setup and Usage

Mounting Orientation

The 402/403/404XE positioner can be mounted in a normal, side, vertical, or inverted orientation. For vertical (Z axis) mounting, care must be taken since certain ballscrew and load combinations can backdrive in a power loss situation. For all orientations, the cables should be secured as to not interfere with the movement of the carriage.

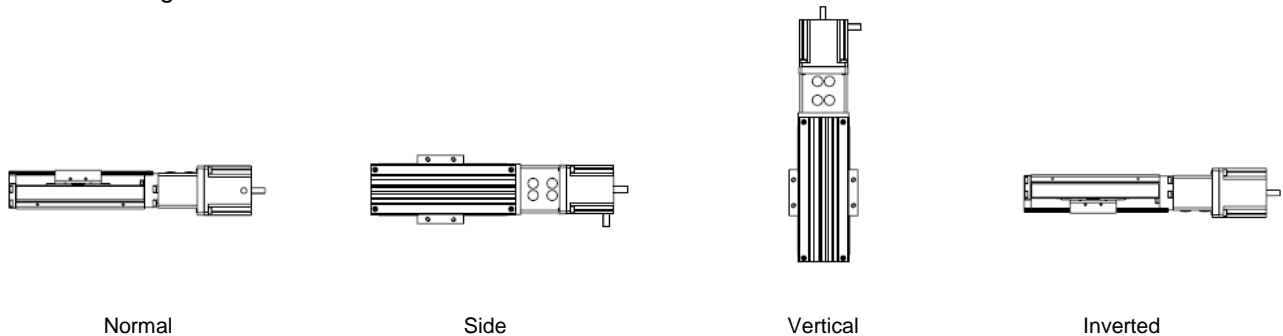

Mounting Surface Requirements

Proper mounting of the 402/403/404XE positioner is essential to optimize product performance. All specifications are based on the following conditions:

- The positioner must be bolted down along its entire length.
- The positioner must be mounted to a flat, stable surface with flatness error less than or equal to 0.013mm/300mm (0.0005"/ft).
- Catalog specifications may deviate for a positioner mounted to a surface that does not meet the above conditions.
- If the surface does not meet the above conditions the surface may be shimmed to comply with these requirements.
- If mounting conditions require that the table base be overhung, catalog specifications will not be met over that portion of the table. Additionally, in X-Y systems the overhung portion of the Y axis may not meet specifications due to the additional error caused by deflection of the unsupported base. Contact factory for guidelines on specifications of overhung applications.

Base Through Hole Mounting - 402/403XE

The 402XE and 403XE have counterbored clearance holes in the base of the unit for mounting. To properly mount the positioner along its entire length, it is required that all counterbored holes be used. See Chapter 2 for hole location and size.

If equipped with a hard cover (R11 & R12 option), the cover needs to be removed to access the holes. To do so, use a 2.0mm hex wrench to remove the two button head screws at each end of the cover.

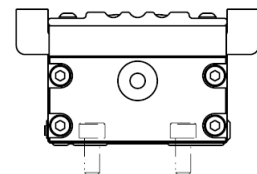

Toe Clamp Mounting - 404XE

The 404XE positioner is mounted via accessory toe clamps that engage the bottom slot in the base profile. To properly mount the positioner along its entire length, toe clamp spacing along the length of the base profile must be no more than 150mm. With short units (T01 and T02 options), a minimum of four clamps is required. See Chapter 2 for toe clamp location, and Appendix A for toe clamp drawing and part number.

The 404XE positioner also includes two dowel pin locating holes in the base to facilitate repeatable installation of the positioner to the mounting surface. These holes are employed for multi-axis applications with standard dowel pinning (P33 & P39 option). See Chapter 2 for dowel pin hole size and location.

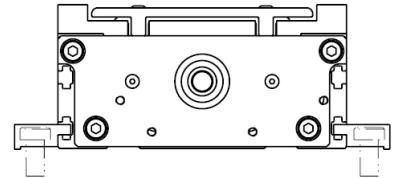

Riser Plates

Most of the motors used with the 402/403/404XE have a taller profile than the positioner. Thus the motor can interfere with the positioner mounting surface. To accommodate taller motors, riser plates can be provided to space the unit above the mounting surface. See Appendix A for riser plate drawings and part numbers.

Payload Mounting

Payload is mounted to the 402/403/404XE using four tapped holes in the carriage. When fastening to the carriage, take precaution in using screws with no more than 13mm of engagement for the 402XE, 15mm of engagement for the 403XE, and 9.5mm of engagement for the 404XE, as to not damage the positioner. See Chapter 2 for hole sizes and locations.

Accessory transition plates are available to build X-Y configurations with various table combinations. If doing so, be certain not to exceed the moment load specifications outlined in Chapter 2. See Appendix A for transition plate drawings and part numbers.

The 404XE positioner also includes two dowel pin locating holes in the carriage to facilitate repeatable installation of payload. These holes are employed for multi-axis applications with standard dowel pinning (P33 & P39 option). See Chapter 2 for dowel pin hole size and location.



Use Appropriate Length Bolt

The 402/403/404XE design requires proper size bolts to be used when mounting payloads to the carriage. Excessive length bolts can cause damage or pin the table in position.

Inline Motor Mounting

Follow the below procedure to install an inline motor to the 402/403/404XE linear positioner.

Tools Required: 2.0mm, 2.5mm, 3.0mm, and 4.0mm Hex Wrenches, Torque Wrench, Loctite 242 or Equivalent

Step 1: Slide coupling onto positioner drive screw shaft and tighten the clamp screw. See Chapter 3 for coupling clamp screw torque specifications. DO NOT use Loctite on coupling screws.

Step 2: Mount motor to motor adapter using appropriate hardware, making sure motor shaft engages coupling bore. Apply Loctite 242 to mounting screw threads prior to assembly.

Step 3: Tighten coupling clamp screw on motor shaft side. See Chapter 3 for coupling clamp screw torque specifications. DO NOT use Loctite on coupling screws. If motor has a rear shaft, rotate motor by rear shaft and check that carriage moves. Hold carriage and attempt to rotate motor by rear shaft to check that coupling does not slip.

Parallel Motor Mounting - 404XE

Follow the below procedure to install the parallel motor mount and motor to the 404XE linear positioner.

Tools Required: 2.0mm, 2.5mm, 3.0mm, and 4.0mm Hex Wrenches, Torque Wrench, Depth Micrometer, Force Gauge, Loctite 609 and 242 or Equivalent

Step 1: Identify the desired parallel mounting position "A", "B", or "C".

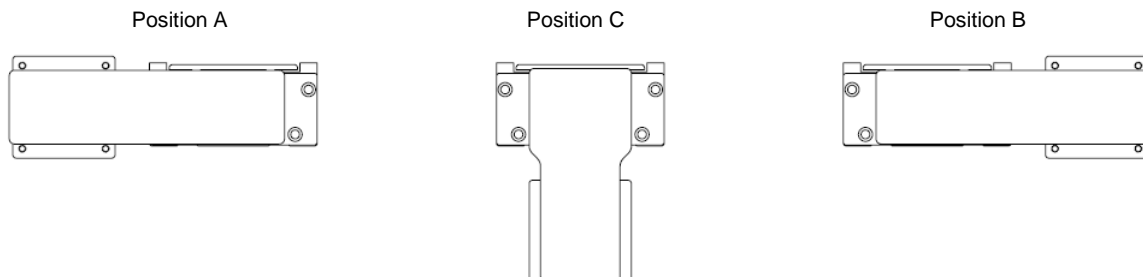

Step 2: Remove any motor, coupling, adapter plate, and motor block previously installed on positioner.

402/403/404XE Series Product Manual

Step 3: IF USING MOTOR POSITION "A" OR "B": Locate parallel mount components for side positions:

Item #	Description
125	(1) Shroud
126	(1) Cover Plate
127	(1) Adapter Plate
128	(2) Pulley
129	(2) Clamp Collar
130	(2) Clamp Collar
131	(1) Belt
132	(1) Belt
515	(4) M4 x 8 Button Head Screw
517	(2) M5 x 10 Button Head Screw
539	(4) M3 x 8 Button Head Screw
540	(2) M5 x 20 Socket Head Cap Screw
541	(4) M4 Ribbed Spring Washer

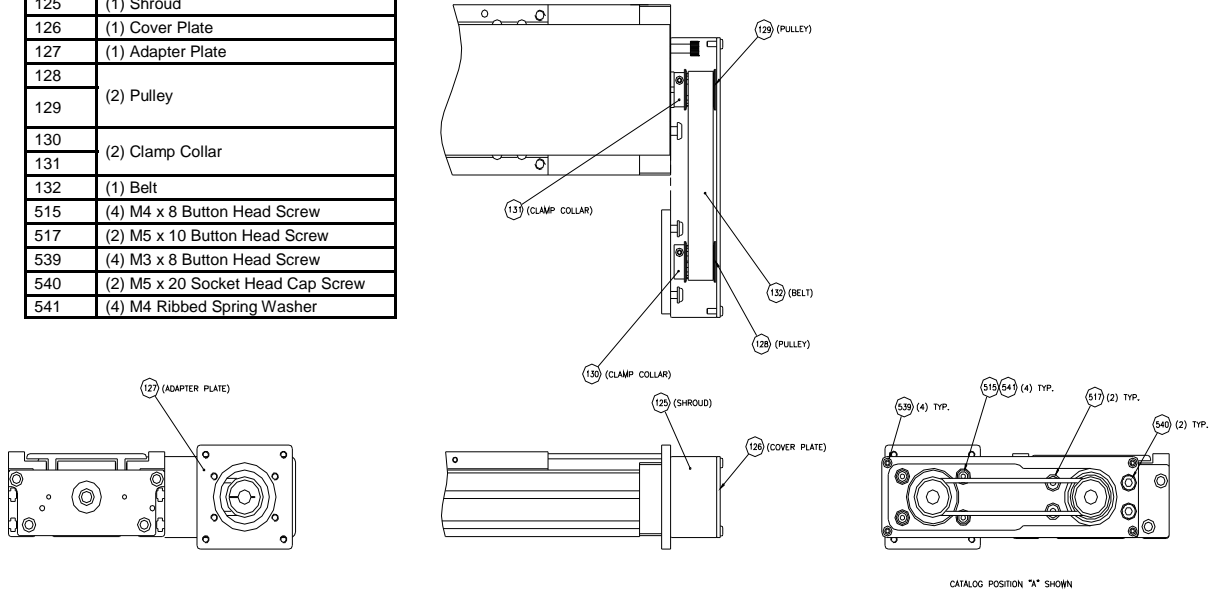

Step 4: IF USING MOTOR POSITION "C": Locate parallel mount components for bottom position:

Item #	Description
125	(1) Shroud
126	(1) Cover Plate
127	(1) Adapter Plate
128	(2) Pulley
129	(2) Pulley
130	(2) Clamp Collar
131	(1) Belt
132	(1) Belt
515	(4) M4 x 8 Button Head Screw
539	(4) M3 x 8 Button Head Screw
540	(4) M5 x 18 Socket Head Cap Screw
541	(4) M4 Ribbed Spring Washer

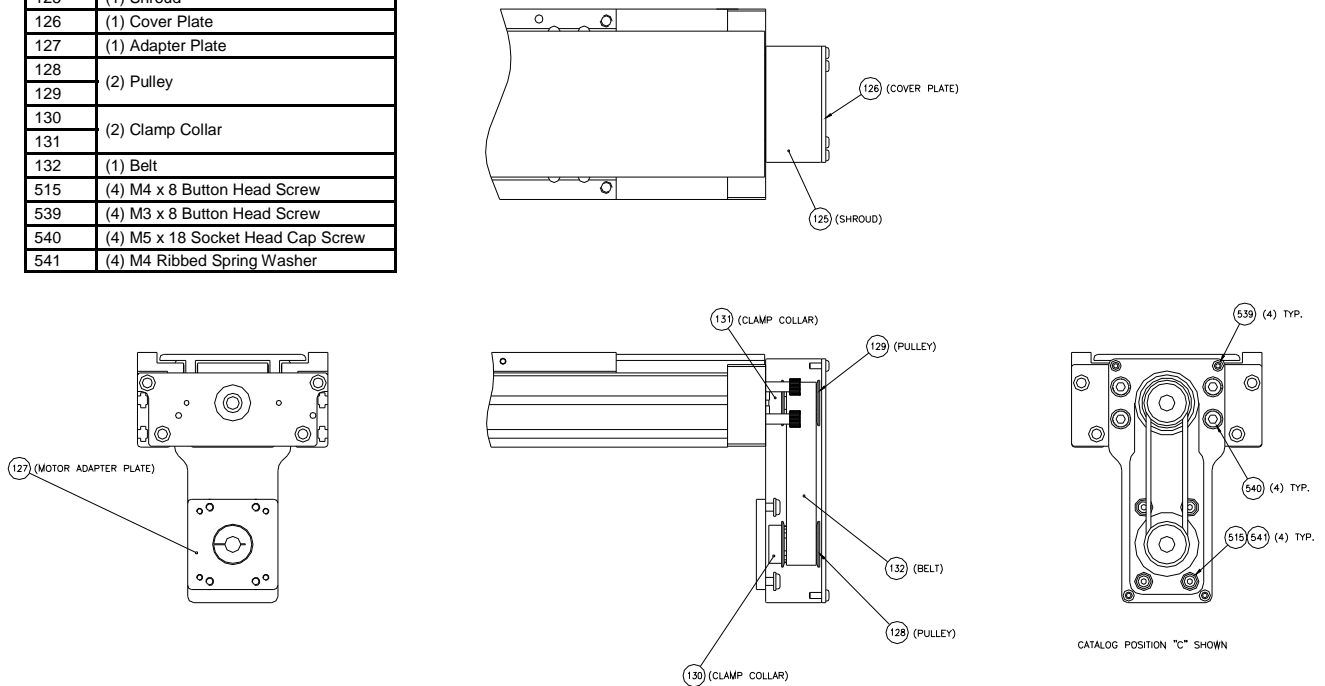

Step 5: Apply Loctite 609 to positioner drive screw shaft. Mount pulley, item #129, with clamp collar, item #131, to screw shaft by sliding it onto the shaft until it contacts the locknut. Tighten clamp screw to 13in-lb.

Step 6: Place shroud, item #125, (less cover plate) over pulley onto positioner in desired orientation. For side positions "A" and "B" install and tighten two (2) socket head cap screws, item #540, through the deep counter-bored holes and install and tighten two (2) button head screws, item #517, through the remaining holes. For bottom position "C" install and tighten four (4) socket head cap screws, item #540, through the deep counter-bored holes. Prior to assembly apply Loctite 242 to the screw threads.

Step 7: Using depth micrometer, measure distance from the open face of the shroud to the face of the pulley flange. The pulley should be recessed some distance from the open face of the shroud. Record this distance.

Step 8: Mount motor adapter plate, item #127, to motor flange using appropriate hardware. Note the motor side of the adapter plate is piloted for the motor. Apply Loctite 242 to screw threads prior to assembly. IT IS CRITICAL that the mounting screws do not protrude through the adapter plate.

Step 9: Apply Loctite 609 to motor shaft and loosely mount pulley, item #128, with clamp collar, item #130, to motor shaft. Place motor/adapter plate assembly against shroud in the mounting position and measure the distance from the open face of the shroud to the face of the pulley. The pulley recess distance should match the distance recorded earlier. Readjust until the distance is matched and tighten clamp screw to 13in-lb. Note once the Loctite 609 is applied, this step should be completed within 10 minutes.

Step 10: Place drive belt, item #132, over drive screw shaft pulley.

Step 11: Place motor/adapter plate assembly against shroud and place belt over motor pulley. Loosely install four (4) button head screws, item #515, with four (4) spring washers, item #541. IT IS CRITICAL that the correct length bolts be used.

Step 12: Tension drive belt by applying a side force of 15lbs to the motor and tighten the mounting screws. Manually traverse the positioner back and forth while observing the belt. The belt should ride in the center of the pulley surfaces (between the flanges). If the belt continually runs against one side of the pulley then alignment needs to be readjusted.

Step 13: Mount cover plate using four (4) button head screws, item #539.

Limit/Home Switch Adjustment - 402/403XE

Travel limit sensors signal the motor to stop whenever the carriage is approaching the end of travel. The home sensor provides a fixed reference point to which the carriage can be commanded to return repeatedly.

If equipped, the 402XE and 403XE limit switches are set at the factory at the ends of travel and the home switch is set at the center of travel. To adjust the switches, loosen the screw that secures the switch into the slot with a flat blade screw driver, slide the switch into the desired position, and retighten.

Printed on the body of the switch is a target (crosshairs). 402XE limit switch settings to utilize full travel are 44mm and 45mm from the target centerline to the end block for the motor and idler locations, respectively. 403XE limit switch settings to utilize full travel are 58mm and 52mm from the target centerline to the end block for the motor and idler locations, respectively.

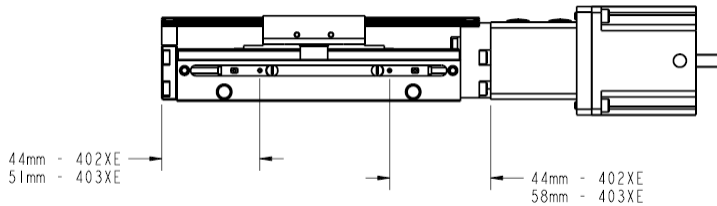

Limit/Home Switch Adjustment - 404XE

If equipped, the 404XE limit switches are set at the factory at the ends of travel and the home switch is set at the center of travel. To adjust the switches, loosen the screw that secures the mounting bracket with a 2.5mm hex wrench, slide the switch into the desired position, and retighten.

If equipped with a sensor pack, the switches are adjusted by loosening the screw that secures the switch in the channel with a #1 Phillips driver. To access these screws, the plastic top cover on the sensor pack needs to be removed. When adjusting the sensor pack switches, the screws may be turned a maximum of 1/4 turn. Any further loosening could result in the nut becoming disengaged. If this occurs the sensor pack will have to be disassembled so that the nut can be reattached.

Printed on the body of the switch is a target (crosshairs). Limit switch settings to utilize full travel for the 404XE with long carriage (VL option) are 85mm and 75mm from the target centerline to the end block for the motor and idler locations, respectively. Limit switch settings to utilize full travel for the 404XE with short carriage (NL option) are 51mm and 42mm from the target centerline to the end block for the motor and idler locations, respectively.

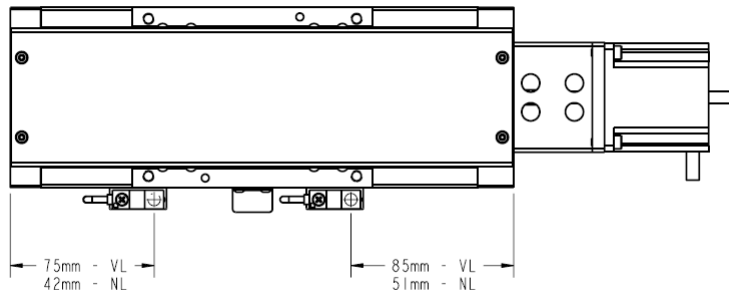

Chapter 5 - Maintenance and Repair

Linear Bearing & Ballscrew Lubrication - 402/403XE

Lubrication Type:

FOR STANDARD PREPARATION (R11 & R13 OPTION): Use *Kyodo Yushi Multemp PS#2*. Contact Kyodo Yushi at +1-630-595-2020 or www.kyodoyushi.co.jp/eng/ for additional technical information, direct purchase or local distributor information.

FOR CLEAN ROOM PREPARATION (R12 & R14 OPTION): Use *Kuroda C-Grease*. Contact Kuroda at +1-773-992-2187 for additional technical information, direct purchase or local distributor information.

Lubricant Appearance:

FOR STANDARD PREPARATION (R11 & R13 OPTION): *Multemp PS#2* - Off-white, smooth but slightly tacky.

FOR CLEANROOM PREPARATION (R12 & R14 OPTION): *C-Grease* - Yellowish-white, paste.

Maintenance Frequency:

FOR BOTH STANDARD AND CLEANROOM PREPARATION: Linear bearings and ballscrews are lubricated at the factory prior to shipment. For lubrication inspection and supply intervals following shipment, apply grease every 1000 hours of usage. The time period may change depending on frequency of use and environment. Inspect for contamination, chips, etc., and replenish according to inspection results.

Lubricant Application:

FOR BOTH STANDARD AND CLEANROOM PREPARATION: Remove hard cover if equipped. Wipe down the bearing guides and screw the entire length with a clean cloth. Apply one pump of lubricant to the grease nipple on the carriage assembly to supply lubricant to the linear bearings. With a small brush apply lubricant on the screw. Traverse the table and repeat if needed.

Notes:

Do not use/mix petroleum base grease with synthetic base grease at any time. For lubrication under special conditions consult factory.

Shorter lubrication interval may be required in environments with high amounts of dust and other contamination.

Linear Bearing & Ballscrew Lubrication - 404XE

Lubrication Type:

FOR STANDARD PREPARATION (R11 & R13 OPTION): For linear bearings, use *Kyodo Yushi Multemp PS#2*. For ballscrew, use *Shell GADUS S2 V100 2*. Contact Kyodo Yushi at +1-630-595-2020 or www.kyodoyushi.co.jp/eng/ for additional technical information, direct purchase or local distributor information. Contact Shell at 800-840-3806 for additional technical information, direct purchase or local distributor information.

FOR CLEAN ROOM PREPARATION (R12 & R14 OPTION): For linear bearings and ballscrew, use *Castrol Braycote 803*. Contact Castrol Industrial at 800-621-2661 for additional technical information, direct purchase or local distributor information.

Lubricant Appearance:

FOR STANDARD PREPARATION (R11 & R13 OPTION): *Multemp PS#2* - Off-white, smooth but slightly tacky. *GADUS S2 V100 2* - Amber, smooth.

FOR CLEANROOM PREPARATION (R12 & R14 OPTION): *Braycote 803* - Translucent-white, smooth and buttery.

Maintenance Frequency:

FOR BOTH STANDARD AND CLEANROOM PREPARATION: Linear bearings and ballscrews are lubricated at the factory prior to shipment. For lubrication inspection and supply intervals following shipment, apply grease every 1000 hours of usage. The time period may change depending on frequency of use and environment. Inspect for contamination, chips, etc., and replenish according to inspection results.

Lubricant Application:

FOR BOTH STANDARD AND CLEANROOM PREPARATION: Remove hard cover if equipped. Wipe down the bearing rails and screw the entire length with a clean cloth. With a small brush apply lubricant on the rails, allowing a film of fresh grease to pass under the wipers and into the bearings. With a small brush apply lubricant on the screw. Traverse the table and repeat if needed.

Notes:

Do not use/mix petroleum base grease with synthetic base grease at any time. For lubrication under special conditions consult factory.

Shorter lubrication interval may be required in environments with high amounts of dust and other contamination.

Brake Installation - 404XE

Follow the below procedure to install the electromagnetic brake (B2 option) on the 404XE:

Tools Required: 2.5mm and 9/16" Hex Wrenches, Dial Indicator, 0.006" Feeler Gauge, Loctite 638 or Equivalent, 24V Power Source

Step 1: Remove power from unit and allow all components to reach room temperature.

Step 2: Clean the counterbore in the idler end of the drive screw shaft that extends through the end block using a clean cloth and acetone or alcohol. Remove all oil or foreign material that might be present.

Step 3: Apply a light film of Loctite 638 to the counterbore.

Step 4: Install the wedge into the end of the mandrel and insert mandrel/wedge assembly into the drive screw shaft counterbore until the mandrel bottoms out at the shoulder. Install the long socket head cap screw and tighten.

Step 5: Verify concentricity of the mandrel. Using a dial indicator, measure the runout (wobble) at the end of the mandrel by manually traversing the table. Runout should not exceed 0.001".

Step 6: Connect the extension cable to the brake and energize the brake by applying 24V supply. See Chapter 3 for wiring information.

Step 7: With the brake energized, slide the magnetic housing over the mandrel. Orient the housing so that the mounting holes align with the tapped holes in the end block. Install and tighten two (2) socket head cap screws

Step 8: Install the clutch with clamp collar onto the mandrel. Use a feeler gauge to set the clutch gap to 0.006". Tighten clamp collar screw and recheck gap.

Step 9: Manually traverse the table over the entire travel and check for unusual noises or dragging while the brake is energized. If rubbing occurs, check mandrel runout. If runout is within tolerance and rubbing persists then reset clutch gap.

Step 10: Remove 24V supply and check that brake engages.

Step 11: Install the brake cover making sure the wires are snug inside the brake cover including the strain relief, and the yellow cable is placed in the wire cavity so that it is not pinched. Install and tighten two (2) socket head cap screws.

Rotary Encoder Installation - 404XE

Follow the below procedure to install the rotary encoder (E5 option) on the 404XE:

Tools Required: 1.5mm, 2.0mm and 0.050" Hex Wrenches, Dial Indicator, Loctite 638 or Equivalent

Step 1: Remove power from unit and allow all components to reach room temperature.

Step 2: Clean the counterbore in the idler end of drive screw shaft that extends through the end block using a clean cloth and acetone or alcohol. Remove all oil or foreign material that might be present.

Step 3: Apply a light film of Loctite 638 to the counterbore.

Step 4: Install the wedge into the end of the mandrel and insert mandrel/wedge assembly into the drive screw shaft counterbore until the mandrel bottoms out at the shoulder. Install the long socket head cap screw and tighten.

Step 5: Verify concentricity of the mandrel. Using a dial indicator, measure the runout (wobble) at the end of the mandrel by manually traversing the table. Runout should not exceed 0.001".

Step 6: Remove cover from rotary encoder assembly. Check to make sure slide lock is all the way out. The slide lock in the outward position provides a seat for the encoder hub during installation to ensure hub is centered properly.

Step 7: Align encoder hub with mandrel and gently push hub onto mandrel until the encoder contacts the end block. DO NOT apply force to any part of the encoder except for the hub.

Step 8: Rotate encoder hub to align the set screw with one of the flats on the mandrel.

Step 9: Maintain pressure on the hub to ensure that it is seated in the centering mechanism and secure hub to mandrel by tightening set screw until in contacts the shaft.

Step 10: Tighten set screw an additional 1/4 turn to apply approximately 20oz-in of torque. Note overtightening will deform the mandrel and cause encoder removal to be difficult.

Step 11: Orient the encoder so that the mounting holes align with the tapped holes in end block. Note standard orientation from the factory is such that the cable egress is at the bottom. Install and tighten two (2) button head screws.

Step 12: Push slide lock in completely. Visually verify that a gap is present between the disk and mask on the underside of the printed circuit board. If no gap is present, remove encoder and reinstall. Manually traverse the table over the entire travel and check that the mandrel and encoder printed circuit board rotate freely without any noises or increased torque.

Step 13: Install cover by snapping it into place.

Appendix A - Accessories & Spare Parts

Part Number	Description
002-1366-32	404XE Coupling, 11mm Bore Oldham
002-1378-05	402XE Coupling, 5mm Bore Oldham
002-1378-07	403XE Coupling, 5mm Bore Oldham
002-1378-09	402XE Coupling, 0.25" Bore Oldham
002-1412-02	404XE Coupling, 0.25" Bore Oldham
002-1412-10	403XE Coupling, 0.375" Bore Oldham
002-1412-14	404XE Coupling, 0.375" Bore Oldham
002-1412-22	403XE Coupling, 0.25" Bore Oldham
002-2813-01	402/403XE Motor Adapter Kit, SM16/BE16 - Includes Adapter and Hardware
002-2814-01	402XE Motor Adapter Kit, NEMA17 - Includes Adapter and Hardware
002-2815-01	402/403XE Motor Adapter Kit, NEMA23/SM23 - Includes Adapter and Hardware
002-2816-01	403XE Motor Adapter Kit, NEMA 17 - Includes Adapter and Hardware
002-2817-01	403XE Riser Plate Kit - Includes Plate and Hardware
002-2818-01	402XE Riser Plate Kit - Includes Plate and Hardware
002-2819-01	Transition Plate Kit, 402T01XE Y Axis, 402XE X Axis - Includes Plate and Hardware
002-2820-01	Transition Plate Kit, 402T02XE to 402T04XE Y Axis, 402XE X Axis - Includes Plate and Hardware
002-2821-01	Transition Plate Kit, 402T01XE or 403T01XE Y Axis, 403XE X Axis - Includes Plate and Hardware
002-2822-01	Transition Plate Kit, 402T02XE to 402T04XE or 403T02XE to 403T08XE Y Axis, 403XE X Axis - Includes Plate and Hardware
002-2823-01	Transition Plate Kit, 402XE or 403XE Y Axis, 404XE X Axis - Includes Plate and Hardware
002-2824-01	402/403XE Motor Adapter Kit, BE23 - Includes Adapter and Hardware
002-2825-01	Transition Plate Kit, LP28 Y Axis to 402XE or 403XE X Axis - Includes Plate, (4) LP28 Toe Clamps, and Hardware
002-3614-01	404XE Motor Adapter Kit, SM16 - Includes Adapter and Hardware
002-3615-01	404XE Motor Adapter Kit, NEMA23/SM23 - Includes Adapter and Hardware
002-3615-02	404XE Motor Adapter Kit, BE23 - Includes Adapter and Hardware
002-3616-01	404XE Motor Block Kit, NEOMETRIC70/SMN060 - Includes Motor Block (Adapter not Needed) and Hardware
002-3617-01	404XE Motor Adapter Kit, NEMA34 - Includes Adapter and Hardware
002-3618-01	404XE Toe Clamp Kit - Includes Clamp and Hardware
002-3619-01	404XE Riser Plate Kit - Includes Plate and Hardware
003-1898-53	404XE Coupling, 0.25" Bore Bellows
003-1898-65	404XE Coupling, 0.375" Bore Bellows
003-1898-76	403XE Coupling, 0.25" Bore Bellows
003-1898-95	404XE Coupling, 11mm Bore Bellows
003-1898-126	402XE Coupling, 0.25" Bore Bellows
003-1898-132	402XE Coupling, 0.375" Bore Bellows
003-1898-133	403XE Coupling, 0.375" Bore Bellows
003-1898-137	402XE Coupling, 5mm Bore Bellows
003-1898-138	403XE Coupling, 5mm Bore Bellows
003-2918-01	404XE Limit/Home 5m Extension Cable

402/403/404XE Series Product Manual

Part Number	Description
006-1627-01	404XE Shaft Brake - For B2 Option
006-1629-01	404XE Rotary Encoder - For E5 Option
006-1639-01	404XE Sensor, N.C. Current Sinking, 2m Cable to Flying Leads - For H2 or L2 Option
006-1639-02	404XE Sensor, N.O. Current Sinking, 2m Cable to Flying Leads - For H3 or L3 Option
006-1639-03	404XE Sensor, N.C. Current Sourcing, 2m Cable to Flying Leads - For H4 or L4 Option
006-1639-04	404XE Sensor, N.O. Current Sourcing, 2m Cable to Flying Leads - For H5 or L5 Option
006-1639-08	404XE Sensor, N.O. Current Sinking, 150mm Cable with Locking Connector- For H7 or L7 Option
006-1639-09	404XE Sensor, N.C. Current Sinking, 150mm Cable with Locking Connector- For H6 or L6 Option
006-1639-10	404XE Sensor, N.O. Current Sourcing, 150mm Cable with Locking Connector- For H9 or L9 Option
006-1639-11	404XE Sensor, N.C. Current Sourcing, 150mm Cable with Locking Connector- For H8 or L8 Option
006-1742-01	402/403/404XE Sensor Pack 3m Extension Cable

See Chapter 2 for motor adapter drawings.

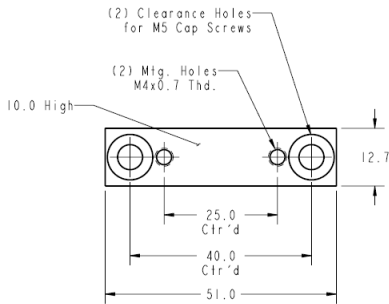

002-2818-01 402XE Riser Plate

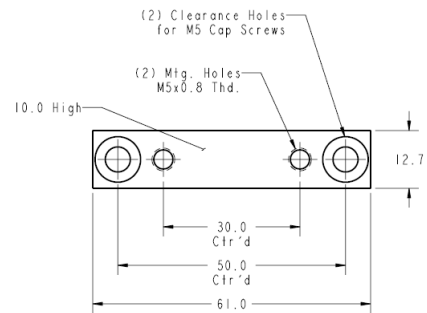

002-2817-01 403XE Riser Plate

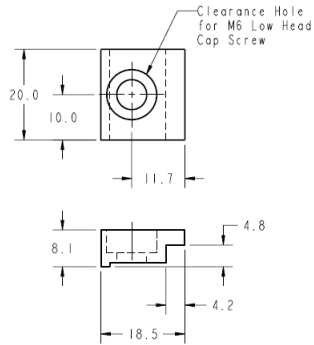

002-3618-01 404XE Toe Clamp

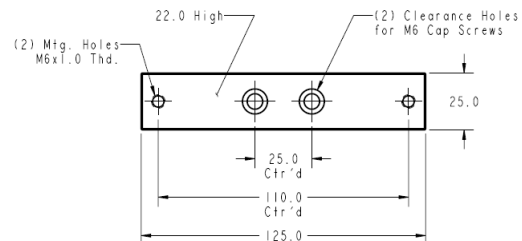

002-3619-01 404XE Riser Plate

402/403/404XE Series Product Manual

X Axis	Y Axis	Part Number	"A"	"B"	"C"	"D"	"E"	"F"
402XE	402T01XE	002-2819-01	120.0	17.5	1	80.0	80.0	4
402XE	402T02XE to 402T04XE	002-2820-01	180.0	7.5	4	40.0	160.0	10

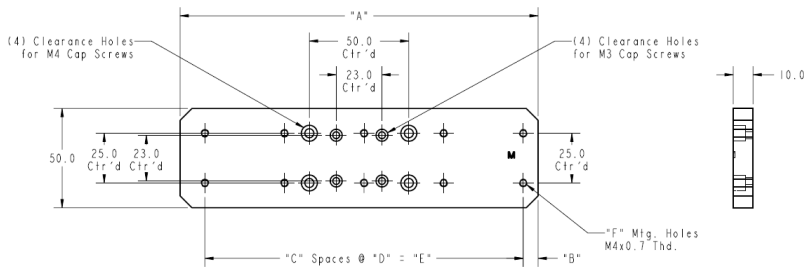

002-2819-01 & 002-2820-01 Transition Plates

X Axis	Y Axis	Part Number	"A"	"B"	"C"	"D"	"E"	"F"	"G"	"H"
403XE	402T01XE or 403T01XE	002-2821-01	120.0	7.5	1	100.0	100.0	4	32.5	80.0
403XE	402T02XE to 402T04XE or 403T02XE to 403T08XE	002-2822-01	211.0	3.0	4	50.0	200.0	10	23.0	160.0

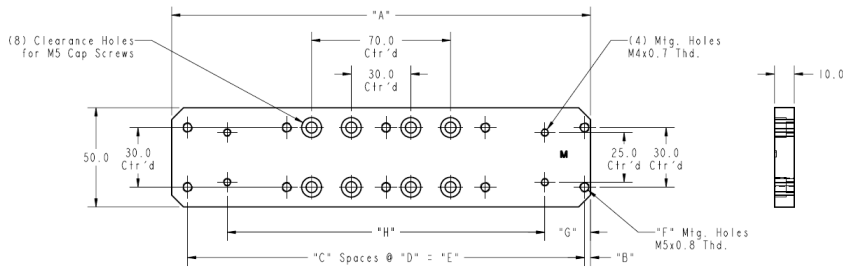

002-2821-01 & 002-2822-01 Transition Plates

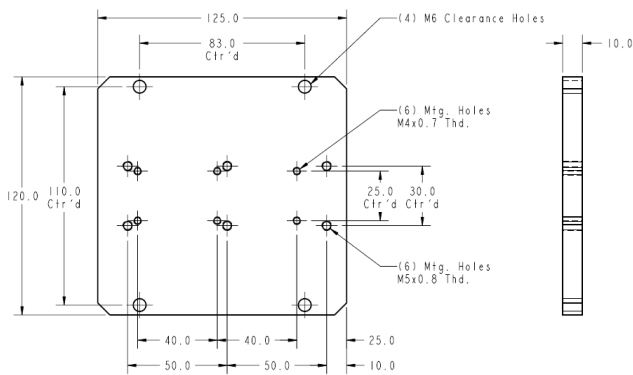

002-2823-01 Transition Plate

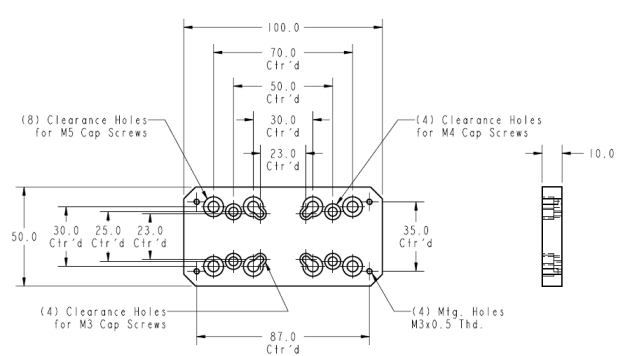

002-2825-01 Transition Plate

Appendix B - Internal Protection

Parker has conducted testing to determine the *degree* to which the positioner is protected by using a British standard called an **Ingress Protection Rating (IP Rating)**. The 402XE and 403XE have an IP 20 protection rating when equipped with hard cover (R11 and R12 option). The 404XE is unrated.

Definition

Reference: British standard EN 60529 : 1992

This standard describes a system of classifying degrees of protection provided by enclosures of electrical equipment. Standardized test methods and the establishment of a two digit numeric rating verify the extent of protection provided against access to hazardous parts, against ingress of solid foreign objects, and against the ingress of water.

First Number: The first number indicates protection of persons against access to dangerous parts and protection of internal equipment against the ingress of solid foreign objects.

- 1 - Protection against access to hazardous parts with the back of a hand, and protected against solid foreign objects of 50 mm diameter and larger.
- 2 - Protection against access to hazardous parts with fingers, and protected against solid foreign objects of 12.5 mm diameter and larger.
- 3 - Protection against access to hazardous parts with a tool, and protected against solid foreign objects of 2.5 mm diameter and larger.

Second Number: The second number indicates protection of internal equipment against harmful ingress of water.

- 0 - No special protection provided.

Note: Number indicators above represent only a partial list of IP Rating specifications.



anything **Parker**
Possible.™

Parker Hannifin Corporation
Electromechanical Automation Division
1140 Sandy Hill Road
Irwin, PA 15642
Tel: (800) 245-6906
www.parkermotion.com
Email: emn_sales@parker.com
emn_support@parker.com

