

Accessories

Couplings



Backlash-free elastomer couplings

Features:

- vibration damping
- electrically insulating (standard)
- backlash-free
- press-fit design
- compensation for lateral-, angular- and axial misalignment

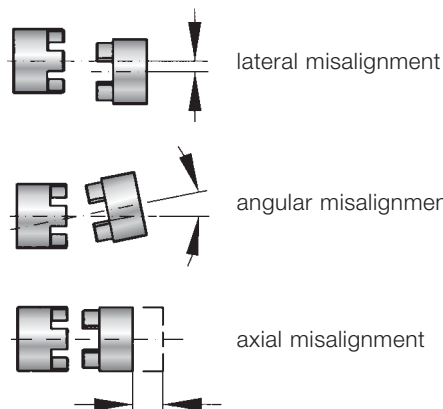

Function elastomer insert

The equalizing element of an EK coupling is the elastomer insert. It transmits the torque without backlash and vibration. The elastomer insert defines the features of the entire coupling and/or of the entire drive system.

The coupling is backlash free due to pretensioning of the elastomer insert between the two coupling halves. The alpha-Coupling compensates for lateral, angular and axial misalignment.



Type A
Shore hardness 98 Sh A



Type B
Shore hardness 64 Sh D





Type C
Shore hardness 80 Sh A

Specification of the elastomer inserts

| Type | Shore hardness | Color | Material | Relative damping (ψ) | Temperature range | Features |
|------|----------------|--------|----------|-----------------------------|-------------------|--------------------------|
| A | 98 Sh A | red | TPU | 0.4-0.5 | -30°C to +100°C | high damping |
| B | 64 Sh D | green | TPU | 0.3-0.45 | -30°C to +120°C | high torsional stiffness |
| C | 80 Sh A | yellow | TPU | 0.3-0.4 | -30°C to +100°C | very high damping |

The values of the relative damping were determined at 10 Hz and +20°C.

| | | Series | | | | | | | | | | | | | | | | | | | | | | | | | | |
|---|--------------------|--------|------|-----|------|------|-----|-----|------|------|------|------|------|------|-------|------|-------|-------|------|-------|-------|------|-------|-------|-------|-------|--------|-------|
| | | 2 | | | 5 | | | 10 | | | 20 | | | 60 | | | 150 | | | 300 | | | 450 | | | 800 | | |
| Type (elastomer insert) | | A | B | C | A | B | C | A | B | C | A | B | C | A | B | C | A | B | C | A | B | C | A | B | C | A | B | C |
| Static torsional stiffness | C_T Nm/rad | 50 | 115 | 17 | 150 | 350 | 53 | 260 | 600 | 90 | 1140 | 2500 | 520 | 3290 | 9750 | 1400 | 4970 | 10600 | 1130 | 12400 | 18000 | 1280 | 15100 | 27000 | 4120 | 41300 | 66080 | 10320 |
| Dynamic torsional stiffness | C_{Tdyn} Nm/rad | 100 | 230 | 35 | 300 | 700 | 106 | 541 | 1650 | 224 | 2540 | 4440 | 876 | 7940 | 11900 | 1350 | 13400 | 29300 | 3590 | 23700 | 40400 | 6090 | 55400 | 81200 | 11600 | 82600 | 180150 | 28600 |
| Lateral  | Max. values mm | 0,08 | 0,06 | 0,1 | 0,08 | 0,06 | 0,1 | 0,1 | 0,08 | 0,12 | 0,1 | 0,08 | 0,15 | 0,12 | 0,1 | 0,15 | 0,15 | 0,12 | 0,2 | 0,18 | 0,14 | 0,25 | 0,2 | 0,18 | 0,25 | 0,25 | 0,2 | 0,3 |
| Angular  | Max. values degree | 1 | 0,8 | 1,2 | 1 | 0,8 | 1,2 | 1 | 0,8 | 1,2 | 1 | 0,8 | 1,2 | 1 | 0,8 | 1,2 | 1 | 0,8 | 1,2 | 1 | 0,8 | 1,2 | 1 | 0,8 | 1,2 | 1 | 0,8 | 1,2 |
| Axial  | Max. values mm | ±1 | | | ±1 | | | ±1 | | | ±2 | | | ±2 | | | ±2 | | | ±2 | | | ±2 | | | ±2 | | |

Static torsional stiffness at 50% T_{R0}

Dynamic torsional stiffness at T_{R0}

XC2 – Elastomer Couplings

| | | | Series | | | | | | | | | | | | | | | | | | | | | | | | | | |
|---|-------------------------------------|-----|---------|-----|-----|------------|----|---|----------|----|---|----------|----|----|-----------|-----|----|-----------|-----|----|-----------|-----|-----|-----------|------|-----|-----------|------|-----|
| | | | 2 | | | 5 | | | 10 | | | 20 | | | 60 | | | 150 | | | 300 | | | 450 | | | 800 | | |
| Type (Elastomer insert) | | | A | B | C | A | B | C | A | B | C | A | B | C | A | B | C | A | B | C | A | B | C | A | B | C | A | B | C |
| Rated torque | T_{KN} | Nm | 2 | 2,4 | 0,5 | 9 | 12 | 2 | 12,5 | 16 | 4 | 17 | 21 | 6 | 60 | 75 | 20 | 160 | 200 | 42 | 325 | 405 | 84 | 530 | 660 | 95 | 950 | 1100 | 240 |
| Max. torque** | T_{Kmax} | Nm | 4 | 4,8 | 1 | 18 | 24 | 4 | 25 | 32 | 6 | 34 | 42 | 12 | 120 | 150 | 35 | 320 | 400 | 85 | 650 | 810 | 170 | 1060 | 1350 | 190 | 1900 | 2150 | 400 |
| Overall length | A | mm | 20 | | | 26 | | | 32 | | | 50 | | | 58 | | | 62 | | | 86 | | | 94 | | | 123 | | |
| Outer diameter | B | mm | 16 | | | 25 | | | 32 | | | 42 | | | 56 | | | 66,5 | | | 82 | | | 102 | | | 136,5 | | |
| Outer diameter with screwhead | B_s | mm | 17 | | | 25 | | | 32 | | | 44,5 | | | 57 | | | 68 | | | 85 | | | 105 | | | 139 | | |
| Mounting length | C | mm | 6 | | | 8 | | | 10,3 | | | 17 | | | 20 | | | 21 | | | 31 | | | 34 | | | 46 | | |
| Inner diameter range H7 | $D_{1/2}$ | mm | 3 bis 8 | | | 4 bis 12,7 | | | 4 bis 16 | | | 8 bis 25 | | | 12 bis 32 | | | 19 bis 36 | | | 20 bis 45 | | | 28 bis 60 | | | 35 bis 80 | | |
| Inner diameter max. (elastomer) | D_E | mm | 6,2 | | | 10,2 | | | 14,2 | | | 19,2 | | | 26,2 | | | 29,2 | | | 36,2 | | | 46,2 | | | 60,5 | | |
| Mounting Screw (ISO 4762/12.9) | E | | M2 | | | M3 | | | M4 | | | M5 | | | M6 | | | M8 | | | M10 | | | M12 | | | M16 | | |
| Tightening torque of the mounting screw | | Nm | 0,6 | | | 2 | | | 4 | | | 8 | | | 15 | | | 35 | | | 70 | | | 120 | | | 290 | | |
| Distance between centers | F | mm | 5,5 | | | 8 | | | 10,5 | | | 15,5 | | | 21 | | | 24 | | | 29 | | | 38 | | | 50,5 | | |
| Distance | G | mm | 3 | | | 4 | | | 5 | | | 8,5 | | | 10 | | | 11 | | | 15 | | | 17,5 | | | 23 | | |
| Hub length | H | mm | 12 | | | 16,7 | | | 20,7 | | | 31 | | | 36 | | | 39 | | | 52 | | | 57 | | | 74 | | |
| Moment of inertia per Hub | $J1/J2 \cdot 10^{-3} \text{ kgm}^2$ | | 0,0003 | | | 0,002 | | | 0,003 | | | 0,01 | | | 0,04 | | | 0,08 | | | 0,3 | | | 0,66 | | | 8 | | |
| Approx. weight | | kg | 0,008 | | | 0,02 | | | 0,05 | | | 0,12 | | | 0,3 | | | 0,5 | | | 0,9 | | | 1,5 | | | 8,5 | | |
| Speed* | | rpm | 28000 | | | 22000 | | | 20000 | | | 19000 | | | 14000 | | | 11500 | | | 9500 | | | 8000 | | | 4000 | | |

Information about static and dynamic torsional stiffness as well as max. possible misalignment see page 329.
 ** Maximum transferable torque of the clamping hub depends on the bore diameters

| Series | Ø 3 | Ø 4 | Ø 5 | Ø 8 | Ø 16 | Ø 19 | Ø 25 | Ø 30 | Ø 32 | Ø 35 | Ø 45 | Ø 50 | Ø 55 | Ø 60 | Ø 65 | Ø 70 | Ø 75 | Ø 80 |
|--------|-----|-----|-----|-----|------|------|------|------|------|------|------|------|------|------|------|------|------|------|
| 2 | 0,2 | 0,8 | 1,5 | 2,5 | | | | | | | | | | | | | | |
| 5 | | 1,5 | 2 | 8 | | | | | | | | | | | | | | |
| 10 | | | 4 | 12 | 32 | | | | | | | | | | | | | |
| 20 | | | | 20 | 35 | 45 | 60 | | | | | | | | | | | |
| 60 | | | | | 50 | 80 | 100 | 110 | 120 | | | | | | | | | |
| 150 | | | | | | 120 | 160 | 180 | 200 | 220 | | | | | | | | |
| 300 | | | | | | 200 | 230 | 300 | 350 | 380 | 420 | | | | | | | |
| 450 | | | | | | | | 420 | 480 | 510 | 600 | 660 | 750 | 850 | | | | |
| 800 | | | | | | | | | | 700 | 750 | 800 | 835 | 865 | 900 | 925 | 950 | 1000 |

Higher torque through additional key possible.

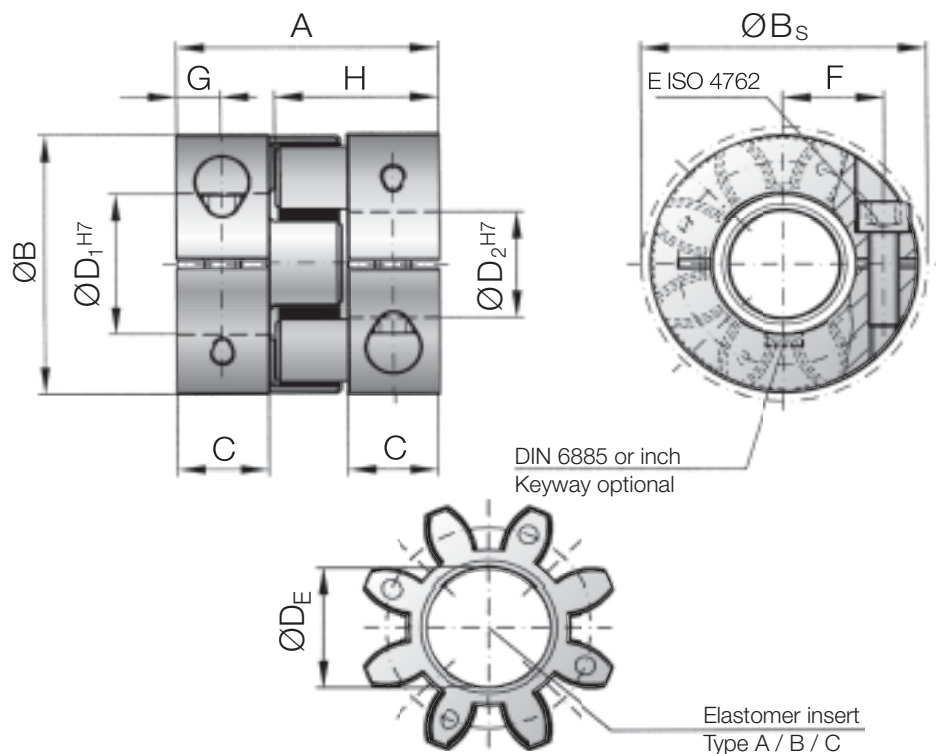

Properties:

- short compact design
- easy assembly
- vibration damping
- electrically insulating
- backlash-free
- press-fit design

Material:

Clamping hub: up to series 450 high strength aluminum, from series 800 and up steel

Elastomer insert: precision molded, wear resistant, and thermally stable polymer

Design:

Two coupling hubs are concentrically machined with concave driving jaws

*Speeds:

Over 4,000 rpm a finely balanced version is available

Tolerance:

On the hub/shaft connection 0.01 to 0.05 mm



XC6 – Elastomer Couplings

| | | | Series | | | | | | | | | | | | | | | | | | | | |
|---|------------|-----------------------------------|----------|----|---|----------|----|----|-----------|-----|----|-----------|-----|----|-----------|-----|-----|-----------|------|-----|-----------|------|-----|
| | | | 10 | | | 20 | | | 60 | | | 150 | | | 300 | | | 450 | | | 800 | | |
| Type (Elastomer insert) | | | A | B | C | A | B | C | A | B | C | A | B | C | A | B | C | A | B | C | A | B | C |
| Rated torque | T_{KN} | Nm | 12,6 | 16 | 4 | 17 | 21 | 6 | 60 | 75 | 20 | 160 | 200 | 42 | 325 | 405 | 84 | 530 | 660 | 95 | 950 | 1100 | 240 |
| Max. torque | T_{Kmax} | Nm | 25 | 32 | 6 | 34 | 42 | 12 | 120 | 150 | 35 | 320 | 400 | 85 | 650 | 810 | 170 | 1060 | 1350 | 190 | 1900 | 2150 | 400 |
| Overall length | A | mm | 42 | | | 56 | | | 64 | | | 76 | | | 96 | | | 110 | | | 138 | | |
| Outer diameter | B | mm | 32 | | | 43 | | | 56 | | | 66 | | | 82 | | | 102 | | | 136,5 | | |
| Mounting length | C | mm | 15 | | | 20 | | | 23 | | | 28 | | | 36 | | | 42 | | | 53 | | |
| Inner diameter range H7 | $D_{1/2}$ | mm | 6 bis 16 | | | 8 bis 24 | | | 12 bis 32 | | | 19 bis 35 | | | 20 bis 45 | | | 28 bis 55 | | | 32 bis 80 | | |
| Inner diameter max. (elastomer) | D_E | mm | 14,2 | | | 19,2 | | | 26,2 | | | 29,2 | | | 36,2 | | | 46,2 | | | 60,5 | | |
| Mounting screw (ISO 4762/12.9) | E | Nm | 3x M3 | | | 6x M4 | | | 4x M5 | | | 8x M5 | | | 8x M6 | | | 8x M8 | | | 8x M10 | | |
| Tightening torque of the mounting screw | | | 2 | | | 3 | | | 6 | | | 7 | | | 12 | | | 35 | | | 55 | | |
| Width Elastomer insert | F | mm | 9,5 | | | 12 | | | 14 | | | 15 | | | 18 | | | 20 | | | 25 | | |
| Moment of inertia per Hub | J1/J2 | 10 ⁻³ kgm ² | 0,004 | | | 0,015 | | | 0,05 | | | 0,1 | | | 0,3 | | | 0,85 | | | 9,2 | | |
| Approx. weight | | kg | 0,08 | | | 0,12 | | | 0,3 | | | 0,5 | | | 0,9 | | | 1,5 | | | 9,6 | | |
| Speed | | rpm | 20000 | | | 19000 | | | 14000 | | | 11500 | | | 9500 | | | 8000 | | | 4000 | | |

Information about static and dynamic torsional stiffness as well as max. possible misalignment see page 329.

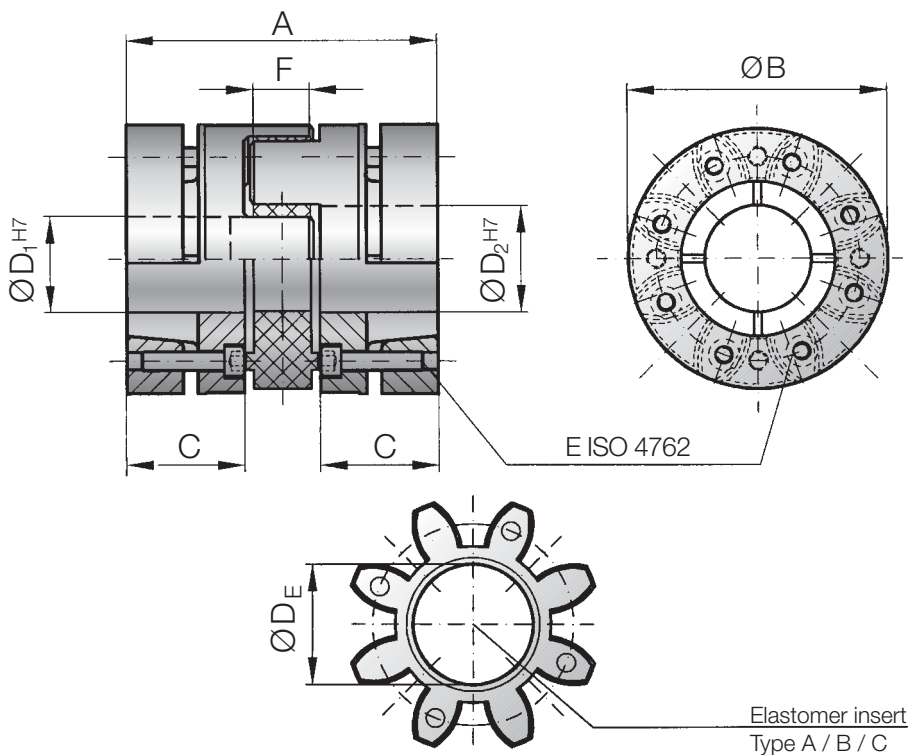

Properties:

- high clamping forces
- concentrically machined
- easy mounting
- damps vibrations
- electrical insulating
- backlash-free
- press-fit design
- axial mounting possible

Material:

Clamping hub and conical clamping: up to series 450 high strength aluminum, from series 800 and up steel
 Elastomer insert: precision molded, wear resistant, and thermally stable polymer

Design:

Two coupling hubs are concentrically machined with concave driving jaws

Tolerance:

On the hub/shaft connection 0.01 to 0.05 mm



TL – Torque limiters

Safe torque limitation

Single position re-engagement – standard version

After the overload has been removed, the torque limiter can be re-engaged precisely 360 degrees from the original disengagement position.

A proven principle that guarantees synchronism. Signal in the event of an overload. Suitable for use in machine tools, packaging machines and automation systems.



Load holding version

In the event of an overload, the drive and the drive elements are not separated or are only allowed limited rotation. Guaranteed load safety. Automatic engagement of the torque limiter after the torque level has dropped. Signal in the event of an overload. Suitable for use on presses or load-lifting equipment.



Multi-position version

Coupling re-engages automatically at the very next ball detent. The coupling is immediately ready for operation again at several points after an overload. Immediate availability of the machine or plant as soon as the overload has been removed. Signal in the event of an overload. Standard engagement after 60 degrees. Optional engagement after 30, 45, 60, 90 and 120 degrees.



Full disengagement version

Permanent separation of the drive and the drive elements in the event of an overload. Spring flips over completely. No residual friction. Torque limiter can be re-engaged manually (re-engagement possible every 60 degrees).

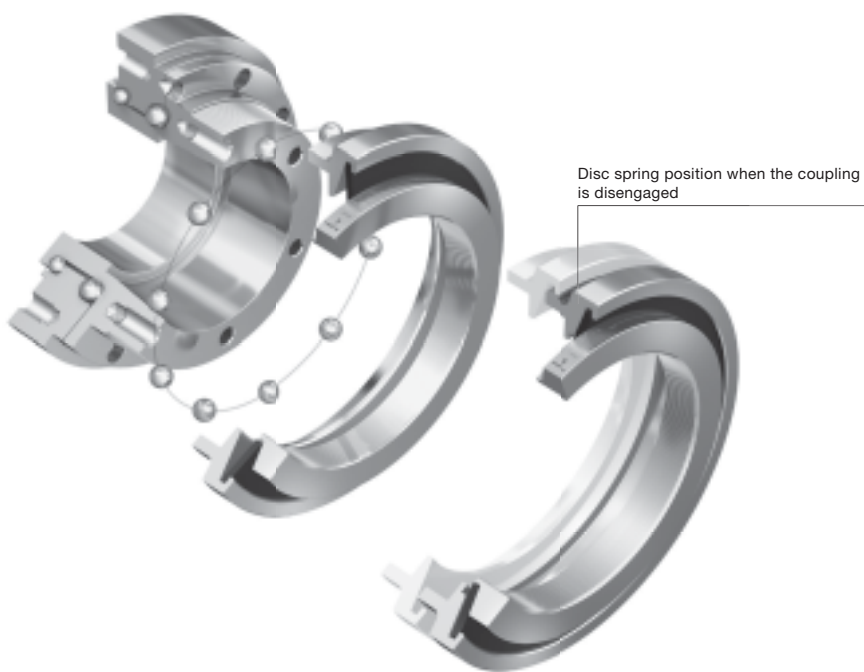

TL1 – Torque limiter

| | | | Series | | | | | | | | | | | | | | |
|--|----------------|---------------------------------------|-------------------------|---------|---------|---------|---------|---------|---------|----------|----------|-----------|-----------|-----------|-----------|-------------|-------------|
| | | | Miniature design series | | | | | | | | | | | | | | |
| | | | 1.5 | 2 | 4.5 | 10 | 15 | 30 | 60 | 150 | 200 | 300 | 500 | 800 | 1500 | 2500 | |
| Adjustment range from – to (approx. values) | T_{KV} | A | Nm | 0.1–0.6 | 0.2–1.5 | 1–3 | 2–6 | 5–15 | 5–20 | 10–30 | 20–70 | 30–90 | 100–200 | 80–200 | 400–650 | 600–800 | 1500–2000 |
| | | | in.lb | 1-6 | 2-14 | 9-27 | 18-54 | 45-133 | 45-177 | 89-266 | 177-620 | 266-797 | 885-1770 | 708-1770 | 3540-5753 | 5310-7080 | 13275-17700 |
| | | B | Nm | 0.4–1 | 0.5–2.2 | 2–4.5 | 4–12 | 12–25 | 10–30 | 25–80 | 45–150 | 60–160 | 150–240 | 200–350 | 500–800 | 700–1200 | 2000–2500 |
| | | | in.lb | 4-9 | 5-20 | 18-40 | 36-107 | 107-222 | 89-266 | 222-708 | 399-1328 | 531-1416 | 1328-2124 | 1770-3098 | 4425-7080 | 6195-10620 | 17700-22125 |
| | | C | Nm | 0.8–2 | 1.5–3.5 | 3–7 | 7–18 | 20–40 | 20–60 | 50–115 | 80–225 | 140–280 | 220–440 | 320–650 | 650–950 | 1000–1800 | 2300–2800 |
| | | | in.lb | 8-18 | 14-31 | 27-62 | 62-160 | 177-354 | 177-531 | 443-1018 | 708-1992 | 1239-2478 | 1947-3894 | 2832-5753 | 5753-8408 | 8850-15930 | 20355-24780 |
| D | Nm | – | – | – | – | 35–70 | 50–100 | – | – | 250–400 | – | – | – | – | – | | |
| | in.lb | – | – | – | – | 310-620 | 443-885 | – | – | 222-3540 | – | – | – | – | – | | |
| Adjustment range from – to (approx. values), full disengagement | T_{KV} | A | Nm | 0.3–0.8 | 0.5–2 | 2.5–4.5 | 2–5 | 7–15 | 8–20 | 10–30 | 20–60 | 80–140 | 120–180 | 50–150 | 200–400 | 1000–1250 | 1400–2200 |
| | | | in.lb | 3-8 | 5-18 | 23-40 | 18-45 | 62-133 | 71-177 | 89-266 | 177-531 | 708-1239 | 1062-1593 | 443-1328 | 1770-3540 | 8850-11063 | 12390-19470 |
| | | B | Nm | 0.6–1.3 | – | – | 4–10 | – | 16–30 | 20–40 | 40–80 | 130–200 | 160–300 | 100–300 | 450–850 | 1250–1500 | 1800–2700 |
| | | | in.lb | 6-12 | – | – | 36-89 | – | 142-266 | 177-354 | 354-708 | 1151-1770 | 1416-2655 | 885-2655 | 3983-7523 | 11063-13275 | 15930-23895 |
| | | C | Nm | – | – | – | 8–15 | – | – | 30–60 | 80–150 | – | – | 250–500 | – | – | |
| | | | in.lb | – | – | – | 71-133 | – | – | 266-531 | 708-1328 | – | – | 2213-4425 | – | – | |
| Overall length | A | mm | 23 | 28 | 32 | 39 | 40 | 50 | 54 | 58 | 63 | 70 | 84 | 95 | 109 | 146 | |
| Overall length, full disengagement | A ^F | mm | 23 | 28 | 32 | 39 | 40 | 50 | 54 | 58 | 66 | 73 | 88 | 95 | 117 | 152 | |
| Outer diameter of actuation ring | B | mm | 23 | 29 | 35 | 45 | 55 | 65 | 73 | 92 | 99 | 120 | 135 | 152 | 174 | 242 | |
| Actuation ring Ø, full disengagement | B ^F | mm | 24 | 32 | 42 | 51.5 | 62 | 70 | 83 | 98 | 117 | 132 | 155 | 177 | 187 | 258 | |
| Clamping fit length | C | mm | 7 | 8 | 11 | 11 | 19 | 22 | 27.5 | 32 | 32 | 41 | 41 | 49 | 61 | 80 | |
| Inner diameter from Ø to Ø H7 | D | mm | 4–8 | 4–12 | 5–14 | 6–20 | 8–22 | 12–22 | 12–29 | 15–37 | 20–44 | 25–56 | 25–56 | 30–60 | 35–70 | 50–100 | |
| Centering diameter h7 | E | mm | 14 | 22 | 25 | 34 | 40 | 47 | 55 | 68 | 75 | 82 | 90 | 100 | 125 | 168 | |
| Hole circle diameter ±0.2 | F | mm | 22 | 28 | 35 | 43 | 47 | 54 | 63 | 78 | 85 | 98 | 110 | 120 | 148 | 202 | |
| Flange diameter – 0.2 | G | mm | 26 | 32 | 40 | 50 | 53 | 63 | 72 | 87 | 98 | 112 | 128 | 140 | 165 | 240 | |
| Thread | H | | 4xM2 | 4xM2.5 | 6xM2.5 | 6xM3 | 6xM4 | 6xM5 | 6xM5 | 6xM6 | 6xM6 | 6xM8 | 6xM8 | 6xM10 | 6xM12 | 6xM16 | |
| Thread length | I | mm | 3 | 4 | 4 | 5 | 6 | 8 | 9 | 10 | 10 | 10 | 12 | 15 | 16 | 24 | |
| Centering length – 0.2 | J | mm | 2.5 | 3.5 | 5 | 8 | 3 | 5 | 5 | 5 | 5 | 6 | 9 | 10 | 13.5 | 20 | |
| Distance | K | mm | 5 | 6 | 8 | 11 | 8 | 11 | 11 | 12 | 12 | 15 | 21 | 19 | 25 | 34 | |
| Distance | L | mm | 11 | 15 | 17 | 22 | 27 | 35 | 37 | 39 | 44 | 47 | 59 | 67 | 82 | 112 | |
| Distance, full disengagement | L ^F | mm | 11.5 | 16 | 18 | 24 | 27 | 37 | 39 | 41.5 | 47 | 51.5 | 62 | 75 | 91 | 120 | |
| Distance | M | | 2.5 | 4 | 4 | 5 | – | – | – | – | – | – | – | – | – | | |
| Screws to ISO 4762 | N | | M2.5 | M3 | M4 | M4 | M4 | M5 | M5 | M6 | M6 | M8 | M8 | M10 | M12 | M16 | |
| Tightening torque | N | Nm | 1 | 2 | 4 | 4.5 | 4 | 6 | 8 | 12 | 14 | 18 | 25 | 40 | 70 | 120 | |
| | | in.lb | 9 | 18 | 36 | 40 | 36 | 54 | 71 | 107 | 124 | 160 | 222 | 354 | 620 | 1062 | |
| Outer diameter of clamping ring | O ₁ | mm | 20 | 25 | 32 | 40 | – | – | – | – | – | – | – | – | – | | |
| Diameter | O ₂ | mm | 13 | 18 | 21 | 30 | 35 | 42 | 49 | 62 | 67 | 75 | 84 | 91 | 112 | 154 | |
| Diameter h7 | O ₃ | mm | 11 | 14 | 17 | 24 | 27 | 32 | 39 | 50 | 55 | 65 | 72 | 75 | 92 | 128 | |
| Distance between centers | P | mm | 6.5 | 8 | 10 | 15 | – | – | – | – | – | – | – | – | – | | |
| Distance | R | mm | 1 | 1.3 | 1.5 | 1.5 | 2.5 | 2.5 | 2.5 | 2.5 | 3 | 3 | 4 | 4 | 4.5 | 6 | |
| Moment of inertia | J | 10 ³ kgm ² | 0.01 | 0.02 | 0.05 | 0.07 | 0.15 | 0.25 | 0.50 | 1.60 | 2.70 | 5.20 | 8.60 | 20 | 31.5 | 210 | |
| | | in.lb.s ² .10 ³ | 0.0089 | 0.0177 | 0.0443 | 0.0620 | 0.1328 | 0.2213 | 0.4425 | 1.4161 | 2.3897 | 4.6024 | 7.6116 | 17.7014 | 27.8797 | 185.86 | |
| Approx. weight | | kg | 0.03 | 0.065 | 0.12 | 0.22 | 0.4 | 0.7 | 1.0 | 1.3 | 2.0 | 3.0 | 4.0 | 5.5 | 10 | 28 | |
| | | lb | 0.066 | 0.143 | 0.265 | 0.485 | 0.882 | 1.543 | 2.205 | 2.866 | 4.409 | 6.614 | 8.818 | 12.125 | 22.046 | 61.729 | |
| Actuation path | | mm | 0.7 | 0.8 | 0.8 | 1.2 | 1.5 | 1.5 | 1.7 | 1.9 | 2.2 | 2.2 | 2.2 | 2.2 | 3.0 | 3.0 | |

A^F, B^F, L^F = Full disengagement version

Torque limiter TL1 (1.5–10)
With clamping hub

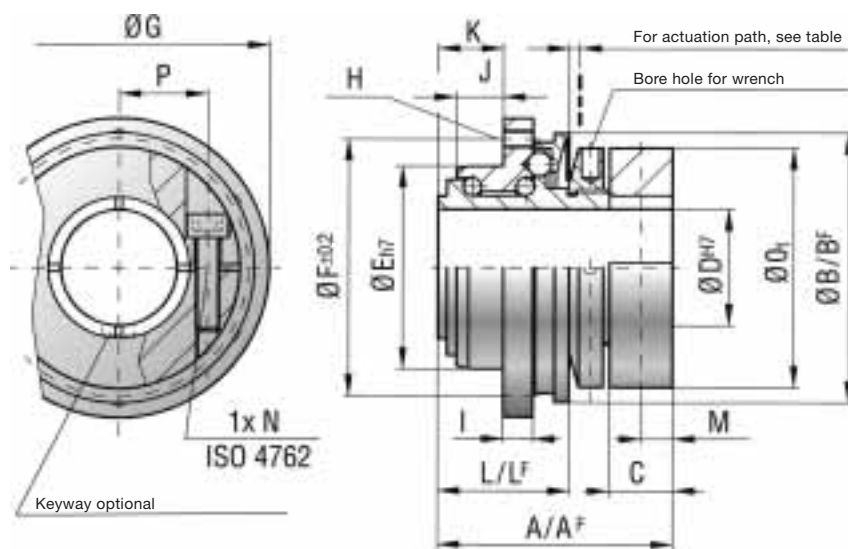

Torque limiter TL1 (15–2500)
With conical clamping hub

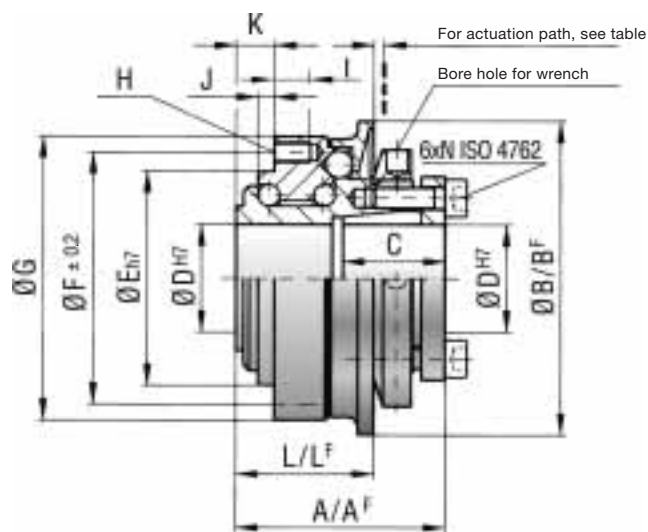

Torque limiter for timing belt and sprocket applications

Material:

High-strength, hardened steel.

Design:

Model TL1: 1.5–10 Nm (13.3 – 88.5 in.lb)
with split clamping hub.

Model TL1: 15–2500 Nm (132.8 – 22125 in.lb)
with conical clamping hub.

Temperature range: -30 °C to +120°C (-22 °F to 248°F)

Temperature peaks: up to +150°C (302°F)

Backlash:

Completely backlash-free as a result of the
frictional clamp connection and patented preload.

Service life:

These torque limiters are permanent and
maintenance-free as long as the performance limits are not
exceeded.

Fit tolerance: Tolerance between shaft and hub 0.01–0.05 mm

TL2 – Torque limiter

| | | | Series | | | | | | | | | | | | | | | | | | | | | | | | | | | | | |
|--|--------------------------------|---------------------------------------|--------|---------|--------|---------|--------|---------|--------|--------|--------|--------|--------|---------|--------|---------|------|---------|------|----------|------|-----------|------|-----------|------|-----------|------|-----------|------|-------------|---|------------|
| | | | 1.5 | | 2 | | 4.5 | | 10 | | 15 | | 30 | | 60 | | 80 | | 150 | | 200 | | 300 | | 500 | | 800 | | 1500 | | | |
| Length options (see ordering code) | | | A | | A | | B | | A | | B | | A | | B | | A | | B | | A | | B | | A | | B | | A | | A | |
| Adjustment range from – to (approx. values) | T_{KN} | Nm | A | 0.1–0.6 | | 0.2–1.5 | | 1–3 | | 2–6 | | 5–10 | | 10–25 | | 10–30 | | 20–70 | | 20–70 | | 30–90 | | 100–200 | | 80–200 | | 400–650 | | 650–800 | | |
| | | | | in.lb | | 1–6 | | 2–14 | | 9–27 | | 18–54 | | 45–89 | | 89–222 | | 89–266 | | 177–620 | | 177–620 | | 266–797 | | 885–1770 | | 708–1770 | | 3540–5753 | | 5753–7080 |
| | | Nm | B | 0.4–1 | | 0.5–2 | | 3–6 | | 4–12 | | 8–20 | | 20–40 | | 25–28 | | 30–90 | | 45–150 | | 60–160 | | 150–240 | | 200–350 | | 500–800 | | 700–1200 | | |
| | | | | in.lb | | 4–9 | | 5–18 | | 27–54 | | 36–107 | | 71–177 | | 177–354 | | 222–248 | | 266–797 | | 399–1328 | | 531–1416 | | 1328–2124 | | 1770–3098 | | 4425–7080 | | 6195–10620 |
| | | Nm | C | 0.8–1.5 | | – | | – | | – | | – | | – | | – | | – | | 80–180 | | 120–240 | | 200–320 | | 300–500 | | 650–850 | | 1000–1800 | | |
| | | | | in.lb | | 8–14 | | – | | – | | – | | – | | – | | – | | 708–1593 | | 1062–2124 | | 1770–2832 | | 2655–4425 | | 5753–7523 | | 8850–15930 | | |
| Adjustment range from – to (approx. values), full disengagement | T_{KN} | Nm | A | 0.3–0.8 | | 0.5–2 | | 2.5–4.5 | | 2–5 | | 7–15 | | 8–20 | | 20–40 | | 20–60 | | 20–60 | | 80–140 | | 120–180 | | 60–150 | | 200–400 | | 1000–1250 | | |
| | | | | in.lb | | 3–8 | | 5–18 | | 23–40 | | 18–45 | | 62–133 | | 71–177 | | 177–354 | | 177–531 | | 177–531 | | 708–1239 | | 1062–1593 | | 531–1328 | | 1770–3540 | | 8850–11063 |
| | | Nm | B | 0.6–1.3 | | – | | – | | 5–10 | | – | | 16–30 | | 30–60 | | 40–80 | | 40–80 | | 130–200 | | 180–300 | | 100–300 | | 450–800 | | 1250–1500 | | |
| | | | | in.lb | | 6–12 | | – | | 45–89 | | – | | 142–266 | | 266–531 | | 354–708 | | 354–708 | | 1151–1770 | | 1593–2655 | | 885–2655 | | 3983–7080 | | 11063–13275 | | |
| | | Nm | C | – | | – | | – | | – | | – | | – | | – | | – | | 80–150 | | – | | – | | 250–500 | | – | | – | | |
| | | | | in.lb | | – | | – | | – | | – | | – | | – | | – | | 708–1328 | | – | | – | | 2213–4425 | | – | | – | | |
| Overall length | A | mm | 42 | 46 | 51 | 57 | 65 | 65 | 74 | 75 | 82 | 87 | 95 | 102 | 112 | 115 | 127 | 116 | 128 | 128 | 140 | 139 | 153 | 163 | 177 | 190 | 223 | | | | | |
| Overall length, full disengagement | A ^F | mm | 42 | 46 | 51 | 57 | 65 | 65 | 74 | 75 | 82 | 87 | 95 | 102 | 112 | 117 | 129 | 118 | 130 | 131 | 143 | 142 | 156 | 167 | 181 | 201 | 232 | | | | | |
| Actuation ring Ø | B | mm | 23 | 29 | 35 | 45 | 55 | 65 | 73 | 92 | 92 | 99 | 120 | 135 | 152 | 174 | | | | | | | | | | | | | | | | |
| Actuation ring Ø, full disengagement | B ^F | mm | 24 | 32 | 42 | 51.5 | 62 | 70 | 83 | 98 | 98 | 117 | 132 | 155 | 177 | 187 | | | | | | | | | | | | | | | | |
| Fit length | C | mm | 11 | 13 | 16 | 16 | 22 | 27 | 31 | 35 | 35 | 40 | 42 | 51 | 48 | 67 | | | | | | | | | | | | | | | | |
| Inner diameter from Ø to Ø H7 | D ₁ /D ₂ | mm | 3–8 | 4–12 | 5–14 | 6–20 | 10–26 | 12–30 | 15–32 | 19–42 | 19–42 | 24–45 | 30–60 | 35–60 | 40–75 | 50–80 | | | | | | | | | | | | | | | | |
| Outer diameter of coupling | E | mm | 19 | 25 | 32 | 40 | 49 | 55 | 66 | 81 | 81 | 90 | 110 | 123 | 134 | 157 | | | | | | | | | | | | | | | | |
| Distance | F | mm | 12 | 13 | 15 | 17 | 19 | 24 | 30 | 31 | 31 | 35 | 35 | 45 | 50 | 65 | | | | | | | | | | | | | | | | |
| Distance, full disengagement | F ^F | mm | 11.5 | 12 | 14 | 16 | 19 | 22 | 29 | 31 | 30 | 33 | 35 | 43 | 54 | 61 | | | | | | | | | | | | | | | | |
| Distance | G | mm | 3.5 | 4 | 5 | 5 | 6.5 | 7.5 | 9.5 | 11 | 11 | 12.5 | 13 | 17 | 18 | 22.5 | | | | | | | | | | | | | | | | |
| Distance between centers | H | mm | 6 | 8 | 10 | 15 | 17 | 19 | 23 | 27 | 27 | 31 | 39 | 41 | 2x48 | 2x55 | | | | | | | | | | | | | | | | |
| Screws to ISO 4762 | I | | M2.5 | M3 | M4 | M4 | M5 | M6 | M8 | M10 | M10 | M12 | M12 | M16 | 2xM16 | 2xM20 | | | | | | | | | | | | | | | | |
| Tightening torque | I | Nm | 1 | 2 | 4 | 4.5 | 8 | 15 | 40 | 50 | 70 | 120 | 130 | 200 | 250 | 470 | | | | | | | | | | | | | | | | |
| | | in.lb | 9 | 18 | 36 | 40 | 71 | 133 | 354 | 443 | 620 | 1062 | 1151 | 1770 | 2213 | 4160 | | | | | | | | | | | | | | | | |
| Approx. weight | | kg | 0.035 | 0.07 | 0.2 | 0.3 | 0.4 | 0.6 | 1.0 | 2.0 | 2.4 | 4.0 | 5.9 | 9.6 | 14 | 21 | | | | | | | | | | | | | | | | |
| | | lb | 0.08 | 0.15 | 0.44 | 0.66 | 0.88 | 1.32 | 2.21 | 4.41 | 5.30 | 8.82 | 13.1 | 21.2 | 30.9 | 46.3 | | | | | | | | | | | | | | | | |
| Moment of inertia | J | 10 ⁻³ kgm ² | 0.01 | 0.01 | 0.01 | 0.02 | 0.02 | 0.06 | 0.07 | 0.10 | 0.15 | 0.27 | 0.32 | 0.75 | 0.80 | 1.80 | 1.90 | 2.50 | 2.80 | 5.10 | 5.30 | 11.5 | 11.8 | 22.8 | 23.0 | 42.0 | 83.0 | | | | | |
| | | 10 ⁻³ in.lb.s ² | 0.0089 | 0.0089 | 0.0089 | 0.0177 | 0.0177 | 0.0531 | 0.0620 | 0.0885 | 0.1328 | 0.2390 | 0.2832 | 0.6638 | 0.7081 | 1.59 | 1.68 | 2.21 | 2.48 | 45.1 | 46.9 | 10.2 | 10.4 | 20.2 | 20.4 | 37.2 | 73.5 | | | | | |
| Torsional rigidity | C _T | 10 ⁻³ Nm/rad | 0.7 | 1.2 | 1.3 | 7 | 5 | 9 | 8 | 20 | 15 | 39 | 28 | 76 | 55 | 129 | 85 | 175 | 110 | 191 | 140 | 420 | 350 | 510 | 500 | 780 | 1304 | | | | | |
| Lateral misalignment | | mm | 0.15 | 0.15 | 0.20 | 0.20 | 0.25 | 0.20 | 0.30 | 0.15 | 0.20 | 0.20 | 0.25 | 0.20 | 0.25 | 0.20 | 0.25 | 0.20 | 0.25 | 0.25 | 0.30 | 0.25 | 0.30 | 0.30 | 0.35 | 0.35 | 0.35 | | | | | |
| Angular misalignment | | degrees | 1 | 1 | 1.5 | 1.5 | 2 | 1.5 | 2 | 1 | 1.5 | 1 | 1.5 | 1 | 1.5 | 1 | 1.5 | 1 | 1.5 | 1.5 | 2 | 1.5 | 2 | 2 | 2.5 | 2.5 | 2.5 | | | | | |
| Lateral spring stiffness | | N/mm | 70 | 40 | 30 | 290 | 45 | 280 | 145 | 475 | 137 | 900 | 270 | 1200 | 420 | 920 | 255 | 1550 | 435 | 2040 | 610 | 3750 | 1050 | 2500 | 840 | 2000 | 3600 | | | | | |
| Actuation path | | mm | 0.7 | 0.8 | 0.8 | 1.2 | 1.5 | 1.5 | 1.7 | 1.9 | 1.9 | 2.2 | 2.2 | 2.2 | 2.2 | 3.0 | | | | | | | | | | | | | | | | |

A^F, B^F, L^F = Full disengagement version
Smaller sizes on request

Torque limiter TL2

With clamping hub

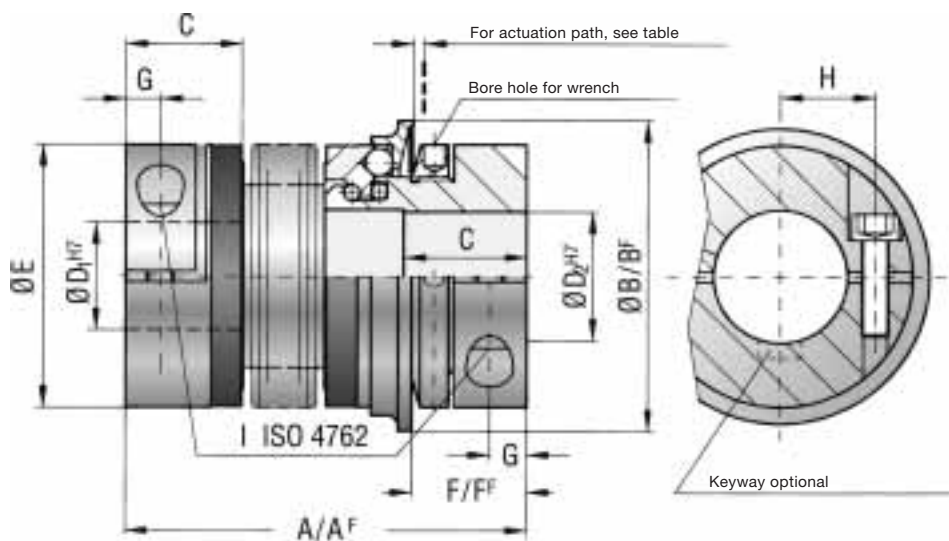

Torque limiter for direct drives

Material:

Bellows made of highly flexible stainless steel. Safety section made of high-strength, hardened steel. Clamping hub material: up to series 80 aluminum and from series 150 steel.

Design:

With clamping hubs and a single lateral screw to ISO 4762.

Temperature range: -30 °C to +120°C (-22 °F to 248 °F)

Backlash:

Completely backlash-free as a result of the frictional clamp connection and patented preload.

Service life:

These torque limiters are permanent and maintenance-free as long as the performance limits are not exceeded.

Fit tolerance: Tolerance between shaft and hub 0.01 – 0.05 mm

TL3 – Torque limiter

| | | | | Series | | | | | | | | | | | | | | | | | |
|---|--------------------------------|---------------------------------------|--------|--------|--------|---------|--------|---------|-------|----------|-------|-----------|-------|-----------|-------|-----------|-------|-----------|--------|-------------|-------------|
| | | | | 15 | | 30 | | 60 | | 150 | | 200 | | 300 | | 500 | | 800 | | 1500 | 2500 |
| Length options (see ordering code) | | | | A | B | A | B | A | B | A | B | A | B | A | B | A | B | A | A | | |
| Adjustment range from – to (approx. values) | T_{KV} | Nm | A | 5–10 | | 10–25 | | 10–30 | | 20–70 | | 30–90 | | 100–200 | | 80–200 | | 400–650 | | 650–850 | 1500–2000 |
| | | | | in.lb | | 45–89 | | 89–222 | | 89–266 | | 177–620 | | 266–797 | | 885–1770 | | 708–1770 | | 3540–5753 | |
| | | Nm | B | 8–20 | | 20–40 | | 25–80 | | 45–150 | | 60–160 | | 150–240 | | 200–350 | | 500–800 | | 700–1200 | 2000–2500 |
| | | | | in.lb | | 71–177 | | 177–354 | | 222–708 | | 399–1328 | | 531–1416 | | 1328–2124 | | 1770–3098 | | 4425–7080 | |
| | | Nm | C | – | | – | | – | | 80–200 | | 140–280 | | 220–400 | | 300–500 | | 600–900 | | 1000–1800 | 2300–2800 |
| | | | | in.lb | | – | | – | | 708–1770 | | 1239–2478 | | 1947–3540 | | 2655–4425 | | 5310–7965 | | 8850–15930 | 20355–24780 |
| Adjustment range from to (approx. values), full engagement | T_{KV} | Nm | A | 7–15 | | 8–20 | | 20–40 | | 20–60 | | 80–140 | | 120–180 | | 60–150 | | 200–400 | | 1000–1250 | 1400–2200 |
| | | | | in.lb | | 62–133 | | 71–177 | | 177–354 | | 177–531 | | 708–1239 | | 1062–1593 | | 531–1328 | | 1770–3540 | |
| | | Nm | B | – | | 16–30 | | 30–60 | | 40–80 | | 130–200 | | 180–300 | | 100–300 | | 450–800 | | 1250–1500 | 1800–2700 |
| | | | | in.lb | | 142–266 | | 266–531 | | 354–708 | | 1151–1770 | | 1593–2655 | | 885–2655 | | 3983–7080 | | 11063–13275 | 15930–23895 |
| | | Nm | C | – | | – | | – | | 80–150 | | – | | – | | 250–500 | | – | | – | – |
| | | | | in.lb | | – | | – | | 708–1328 | | – | | – | | 2213–4425 | | – | | – | – |
| Overall length | A | mm | 62 | 69 | 72 | 80 | 84 | 94 | 93 | 105 | 99 | 111 | 114 | 128 | 123 | 136 | 151 | 175 | 246 | | |
| Overall length, full disengagement | A ^F | mm | 62 | 69 | 72 | 80 | 84 | 94 | 93 | 105 | 102 | 114 | 117 | 131 | 127 | 140 | 151 | 184 | 252 | | |
| Actuation ring Ø | B | mm | 55 | | 65 | | 73 | | 92 | | 99 | | 120 | | 135 | | 152 | 174 | 243 | | |
| Actuation ring Ø, full disengagement | B ^F | mm | 62 | | 70 | | 83 | | 98 | | 117 | | 132 | | 155 | | 177 | 187 | 258 | | |
| Fit length | C | mm | 19 | | 22 | | 27 | | 32 | | 32 | | 41 | | 41 | | 49 | 61 | 80 | | |
| Inner diameter from Ø to Ø H7 | D ₁ /D ₂ | mm | 10–22 | | 12–23 | | 12–29 | | 15–37 | | 20–44 | | 25–56 | | 25–60 | | 30–60 | 35–70 | 50–100 | | |
| Outer diameter of coupling | E | mm | 49 | | 55 | | 66 | | 81 | | 90 | | 110 | | 123 | | 133 | 157 | 200 | | |
| Distance | F | mm | 13 | | 16 | | 18 | | 19 | | 19 | | 23 | | 25 | | 31 | 30 | 34 | | |
| Distance, full disengagement | F ^F | mm | 13 | | 14 | | 17 | | 18 | | 17 | | 20 | | 22 | | 20 | 26 | 31 | | |
| 6xscrews to ISO 4017 | I | | M4 | | M5 | | M5 | | M6 | | M6 | | M8 | | M8 | | M10 | M12 | M16 | | |
| Tightening torque | I | Nm | 4 | | 6 | | 8 | | 12 | | 14 | | 18 | | 25 | | 40 | 70 | 120 | | |
| | | in.lb | 36 | | 54 | | 71 | | 107 | | 124 | | 160 | | 222 | | 354 | 620 | 1062 | | |
| Approx. weight | | kg | 0.3 | | 0.4 | | 1.2 | | 2.3 | | 3.0 | | 5.0 | | 6.5 | | 9.0 | 16.3 | 35 | | |
| | | lb | 0.66 | | 0.88 | | 2.65 | | 5.07 | | 6.61 | | 11.0 | | 14.3 | | 19.8 | 35.9 | 77.2 | | |
| Moment of inertia | J | 10 ⁻³ kgm ² | 0.10 | 0.15 | 0.28 | 0.30 | 0.75 | 0.80 | 1.90 | 2.00 | 2.80 | 3.00 | 5.50 | 6.00 | 11.0 | 12.8 | 20.00 | 42.00 | 257 | | |
| | | 10 ⁻³ in.lb.s ² | 0.0885 | 0.1328 | 0.2478 | 0.2655 | 0.6638 | 0.7081 | 1.68 | 1.77 | 2.48 | 2.66 | 4.87 | 5.31 | 9.74 | 11.3 | 17.7 | 37.2 | 227.5 | | |
| Torsional rigidity | C _r | 10 ³ Nm/rad | 20 | 15 | 39 | 28 | 76 | 55 | 175 | 110 | 191 | 140 | 420 | 350 | 510 | 500 | 780 | 1304 | 3400 | | |
| Lateral misalignment | | mm | 0.15 | 0.20 | 0.20 | 0.25 | 0.20 | 0.25 | 0.20 | 0.25 | 0.25 | 0.30 | 0.25 | 0.30 | 0.30 | 0.35 | 0.35 | 0.35 | 0.35 | | |
| Angular misalignment | | degrees | 1 | 1.5 | 1 | 1.5 | 1 | 1.5 | 1 | 1.5 | 1.5 | 2 | 1.5 | 2 | 2 | 2.5 | 2.5 | 2.5 | 2.5 | | |
| Lateral spring stiffness | | N/mm | 475 | 137 | 900 | 270 | 1200 | 380 | 1550 | 435 | 2040 | 610 | 3750 | 1050 | 2500 | 840 | 2000 | 3600 | 6070 | | |
| Actuation path | | mm | 1.5 | | 1.5 | | 1.7 | | 1.9 | | 2.2 | | 2.2 | | 2.2 | | 2.2 | 3 | 3 | | |

A^F, B^F, F^F = Full disengagement version

Torque limiter TL3

With conical clamp connection

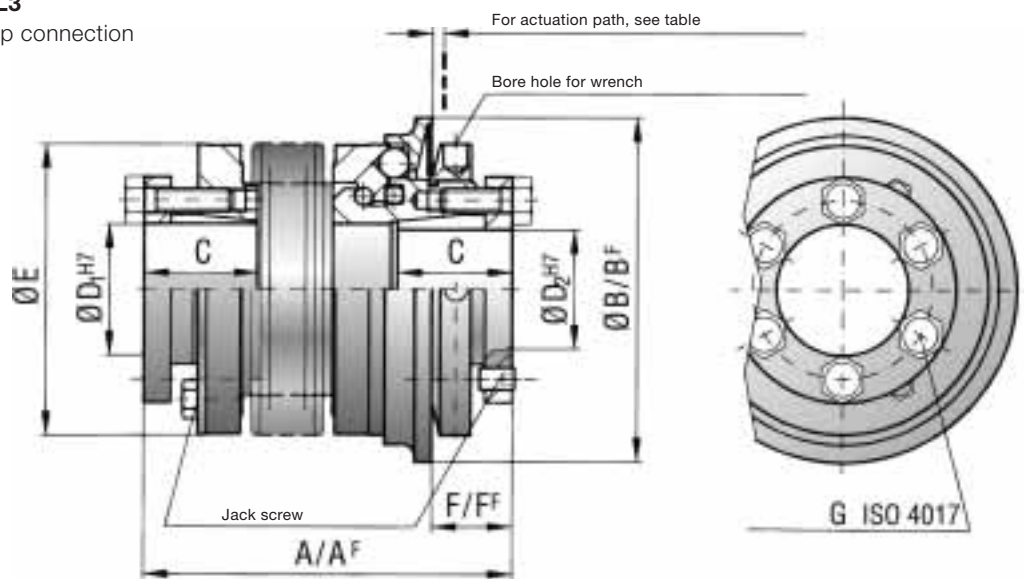

Torque limiter for direct drives

Material:

Bellows made of highly flexible stainless steel. Safety section made of high-strength, hardened steel. Hub material: steel.

Design:

With split conical clamping hubs and captive jack screws.

Temperature range: -30 °C to +120°C (-22 °F to 248 °F)

Backlash:



Completely backlash-free as a result of the frictional clamp connection and patented preload.

Service life:

These torque limiters are permanent and maintenance-free as long as the performance limits are not exceeded.

Fit tolerance: Tolerance between shaft and hub 0.01 – 0.05 mm

BCT – Bellows coupling

| | | Series | | | | |
|--|--|-----------------|---------------|---------------|----------------|-----------------|
| | | 15 | 60 | 150 | 300 | 1500 |
| Gearhead output type | | TP* 004 | TP* 010 | TP* 025 | TP* 050 | TP* 110 |
| Centering diameter | D_2 mm | 40 h7 | 63 h7 | 80 h7 | 100 h7 | 160 h7 |
| TP flange hole circle diameter / thread | D_3 mm | 31.5 8 x M5 | 50 8 x M6 | 63 12 x M6 | 80 12 x M8 | 125 12 x M10 |
| Nominal torque | T_{KN} Nm in.lb | 40 | 140 | 220 | 400 | 1570 |
| | | 354 | 1239 | 1947 | 3540 | 13895 |
| Length 2 | A_1 mm | 49 | 67 | 72 | 90 | 140 |
| Length installation space 2 | A_2 mm | 68 | 97 | 101 | 128 | 190 |
| Hub diameter | B_1 mm | 49 | 66 | 82 | 110 | 157 |
| Flange diameter | B_2 mm | 63.5 | 86.5 | 108 | 132 | 188 |
| Fit length | C_1 mm | 16.5 | 23 | 27.5 | 34 | 55 |
| Possible inner diameter from \emptyset to \emptyset H7 | D_1 mm | 12 - 28 | 14 - 35 | 19 - 42 | 24 - 60 | 50 - 80 |
| Hole circle diameter / Thread | DL mm | 56.5 10 x M4 | 76 10 x M5 | 97 10 x M6 | 120 12 x M6 | 170 16 x M8 |
| Screws to ISO 4762 | E | 1 x M5 | 1 x M8 | 1 x M10 | 1 x M12 | 2 x M20 |
| Tightening torque of fastening screw | E Nm in.lb | 8 | 45 | 80 | 120 | 470 |
| | | 71 | 399 | 708 | 1062 | 4160 |
| Distance | G mm | 6.5 | 9.5 | 11 | 13 | 22.5 |
| Approx. weight | I kg lb | 0.3 | 0.7 | 1 | 2.8 | 10 |
| | | 0.67 | 1.55 | 2.21 | 6.18 | 22.05 |
| Torsional rigidity | C_T 10^3 Nm/rad 10^3 lb/rad | 23 | 72 | 141 | 536 | 1304 |
| | | 204 | 637 | 1248 | 4744 | 11540 |
| Moment of inertia | J 10^{-3} kgm ² 10^{-3} in.lb.s ² | 0.15 | 0.65 | 1.3 | 5.5 | 45 |
| | | 0.14 | 0.58 | 1.16 | 4.87 | 39.83 |
| Axial misalignment  | Max. values mm | 1 | 1.5 | 2 | 2.5 | 3 |
| Lateral misalignment  | Max. values mm | 0.25 | 0.25 | 0.25 | 0.25 | 0.2 |

Max. angular misalignment 1°



Low backlash metal bellows coupling BCT

With flange connection

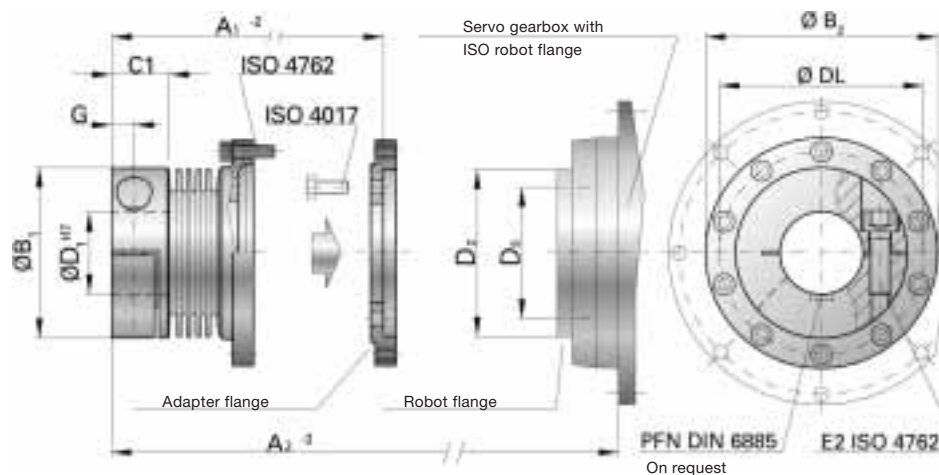

Installation and removal

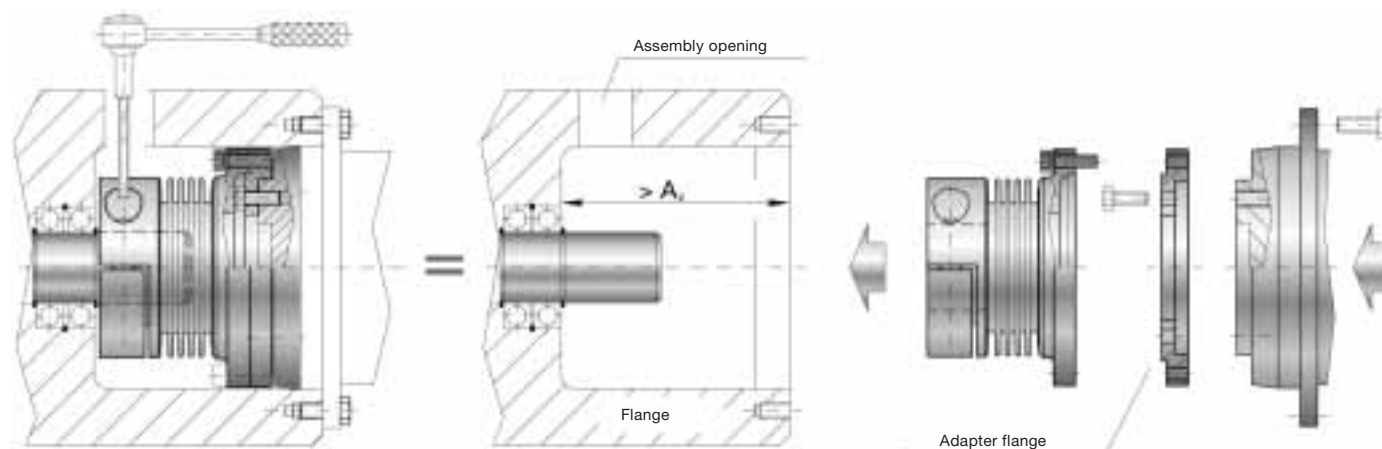

Bellows coupling for direct drives

Material:

Hub: Series 15-150 high-strength alu,
Series: 300-1500 steel,
Bellows: High-strength stainless steel,
Adapter flange: Steel

Design:

Load side: With clamping hubs and a single lateral screw to ISO 4762.
Gearbox side: With flange connection and separate adapter flange.

Temperature range: -30 °C to +120°C, (-22 °F to 248°F)

Fit tolerance: Tolerance between shaft and hub 0.01 – 0.05 mm



Speeds:

Up to 10000 rpm

Non-standard applications:

Custom designs with different tolerances, keyways, non-standard material, bellows are available at short notice.

BC2 – Bellows coupling

| | | | Series | | | | | | | | | | | | | | | | | | | |
|--|-----------|----------------------------|--------|--------|--------|--------|--------|--------|--------|--------|-------|------|-------|------|-------|------|--------|-------|---------------------|------|---------------------|--|
| | | | 15 | | 30 | | 60 | | 80 | | 150 | | 200 | | 300 | | 500 | | 800 | 1500 | | |
| Length options (see ordering code) | | | A | B | A | B | A | B | A | B | A | B | A | B | A | B | A | B | A | A | | |
| Rated torque | T_{KN} | Nm | 15 | | 30 | | 60 | | 80 | | 150 | | 200 | | 300 | | 500 | | 800 | | 1500 | |
| | | in.lb | 133 | | 266 | | 531 | | 708 | | 1328 | | 1770 | | 2655 | | 4425 | | 7080 | | 13275 | |
| Overall length | A | mm | 59 | 66 | 69 | 77 | 83 | 93 | 94 | 106 | 95 | 107 | 105 | 117 | 111 | 125 | 133 | 146 | 140 | | 166 | |
| Outer diameter | B | mm | 49 | | 55 | | 66 | | 81 | | 81 | | 90 | | 110 | | 124 | | 134 | | 157 | |
| Fit length | C | mm | 22 | | 27 | | 31 | | 36 | | 36 | | 41 | | 43 | | 51 | | 45 | | 55 | |
| Inner diameter from \varnothing to \varnothing H7 | D_1/D_2 | mm | 8–28 | | 10–30 | | 12–32 | | 14–42 | | 19–42 | | 22–45 | | 24–60 | | 35–60 | | 40–75 | | 50–80 | |
| Fastening screws to ISO 4762 | E | | M5 | | M6 | | M8 | | M10 | | M10 | | M12 | | M12 | | M16 | | 2xM16 ^{a)} | | 2xM20 ^{a)} | |
| | | | 71 | | 133 | | 354 | | 443 | | 620 | | 1062 | | 1151 | | 1770 | | 2213 | | 4160 | |
| Distance between centers | F | mm | 17 | | 19 | | 23 | | 27 | | 27 | | 31 | | 39 | | 41 | | 2x48 | | 2x55 | |
| Distance | G | mm | 6.5 | | 7.5 | | 9.5 | | 11 | | 11 | | 12.5 | | 13 | | 16.5 | | 18 | | 22.5 | |
| Moment of inertia | J | 10^{-3}kgm^2 | 0.05 | 0.07 | 0.12 | 0.13 | 0.32 | 0.35 | 0.8 | 0.85 | 1.9 | 2 | 3.2 | 3.4 | 7.6 | 7.9 | 14.3 | 14.6 | 16.2 | | 43.5 | |
| | | 10^{-3}in.lb.s^2 | 0.0443 | 0.0620 | 0.1062 | 0.1151 | 0.2832 | 0.3098 | 0.7081 | 0.7523 | 1.68 | 1.77 | 2.83 | 3.01 | 6.73 | 6.99 | 12.66 | 12.92 | 14.34 | | 38.50 | |
| Hub material (standard) (steel on request) | | | Al | | Al | | Al | | Al | | Steel | | Steel | | Steel | | Steel | | Steel | | Steel | |
| Approx. weight | | kg | 0.16 | | 0.26 | | 0.48 | | 0.8 | | 1.85 | | 2.65 | | 4 | | 6.3 | | 5.7 | | 11.5 | |
| | | lb | 0.353 | | 0.573 | | 1.764 | | 1.764 | | 4.079 | | 5.842 | | 8.818 | | 13.889 | | 12.566 | | 25.353 | |
| Torsional rigidity | C_T | 10^3Nm/rad | 20 | 15 | 39 | 28 | 76 | 55 | 129 | 85 | 175 | 110 | 191 | 140 | 450 | 350 | 510 | 500 | 780 | | 1304 | |
| Axial misalignment  | | max. values mm | 1 | 2 | 1 | 2 | 1.5 | 2 | 2 | 3 | 2 | 3 | 2 | 3 | 2.5 | 3.5 | 2.5 | 3.5 | 3.5 | | 3.5 | |
| Lateral misalignment  | | max. values mm | 0.15 | 0.2 | 0.2 | 0.25 | 0.2 | 0.25 | 0.2 | 0.25 | 0.2 | 0.25 | 0.25 | 0.3 | 0.25 | 0.3 | 0.3 | 0.35 | 0.35 | | 0.35 | |
| Axial spring stiffness | C_a | N/mm | 25 | 15 | 50 | 30 | 72 | 48 | 48 | 32 | 82 | 52 | 90 | 60 | 105 | 71 | 70 | 48 | 100 | | 320 | |
| Lateral spring stiffness | C_r | N/mm | 475 | 137 | 900 | 270 | 1200 | 420 | 920 | 290 | 1550 | 435 | 2040 | 610 | 3750 | 1050 | 2500 | 840 | 2000 | | 3600 | |

^{a)} Two screws per clamping hub, 180° apart
Max. angular misalignment 1.5°

Bellows coupling BC2

With clamping hub

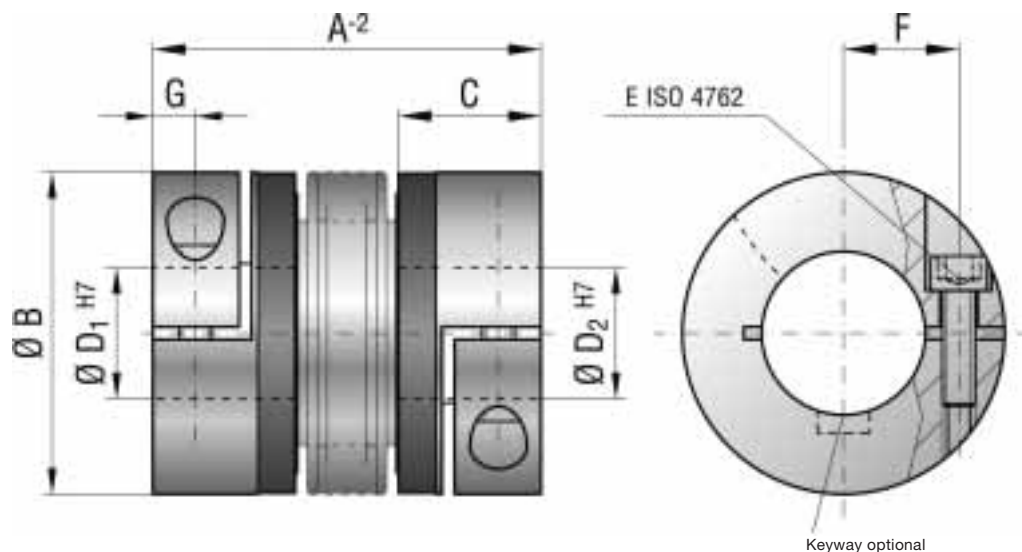

Bellows coupling for direct drives

Material:

Bellows made of highly flexible stainless steel.
Hub material: see table below.

Design:

With clamping hubs and a single lateral screw to ISO 4762.
Any imbalance of the clamping hubs due to the design is compensated by balancing bores located on the hub interior.

Temperature range: -30 °C to +120°C (-22 °F to 248 °F)

Backlash:

Completely backlash-free as a result of the frictional clamp connection.

Service life:

These torque limiters are permanent and maintenance-free as long as the performance limits are not exceeded.



Fit tolerance: Tolerance between shaft and hub 0.01–0.05 mm

Speeds:

Up to 10,000 rpm / in excess of 10,000 rpm with finely balanced version.

Brief overload: Acceptable up to 1.5 times the value specified.

BC3 – Bellows coupling

| | | | Series | | | | | | | | | | | | | | | | | | |
|--|--------------------|--|--------|-------|-------|------|-------|------|-------|------|-------|------|-------|------|-------|------|-------|-------|--------|--------|--------|
| | | | 15 | | 30 | | 60 | | 150 | | 200 | | 300 | | 500 | | 800 | 1500 | 4000 | 6000 | 10000 |
| Length options (see ordering code) | | | A | B | A | B | A | B | A | B | A | B | A | B | A | A | A | A | A | | |
| Rated torque | T_{KN} | Nm in.lb | 15 | | 30 | | 60 | | 150 | | 200 | | 300 | | 500 | | 800 | 1500 | 4000 | 6000 | 10000 |
| | | | 133 | | 266 | | 531 | | 1328 | | 1770 | | 2655 | | 4425 | | 7080 | 13275 | 35400 | 53100 | 88500 |
| Overall length without screw head | A | mm | 48 | 55 | 57 | 65 | 66 | 76 | 75 | 87 | 78 | 90 | 89 | 103 | 97 | 110 | 114 | 141 | 195 | 210 | 217 |
| Outer diameter | B | mm | 49 | | 55 | | 66 | | 81 | | 90 | | 110 | | 124 | | 133 | 157 | 200 | 253 | 303 |
| Fit length | C | mm | 19 | | 22 | | 27 | | 32 | | 32 | | 41 | | 41 | | 50 | 61 | 80 | 85 | 92 |
| Inner diameter from \emptyset to \emptyset H7 | D_1/D_2 | mm | 10–22 | | 12–23 | | 12–29 | | 15–38 | | 15–44 | | 24–56 | | 24–60 | | 30–60 | 35–70 | 50–100 | 60–140 | 70–180 |
| 6x fastening screws to ISO 4017 | E | | M4 | | M5 | | M5 | | M6 | | M6 | | M8 | | M8 | | M10 | M12 | M16 | M16 | 8xM16 |
| Tightening torque of fastening screws | E | Nm in.lb | 4 | | 6 | | 8 | | 12 | | 14 | | 18 | | 25 | | 40 | 70 | 120 | 150 | 160 |
| | | | 36 | | 54 | | 71 | | 107 | | 124 | | 160 | | 222 | | 354 | 620 | 1062 | 1328 | 1416 |
| 3x jack screws to ISO 4017 | F | | M4 | | M4 | | M5 | | M5 | | M6 | | M6 | | M6 | | M6 | 6xM8 | 6xM10 | 6xM10 | 8xM10 |
| Outer diameter of hub | G | mm | 49 | | 55 | | 66 | | 81 | | 90 | | 110 | | 122 | | 116 | 135 | 180 | 246 | 295 |
| Moment of inertia | J | 10^{-3}kgm^2 10^{-3}in.lb.s^2 | 0.08 | 0.08 | 0.15 | 0.16 | 0.39 | 0.41 | 1.2 | 1.6 | 1.7 | 2.5 | 5.1 | 5.9 | 9.1 | 9.9 | 13.2 | 34.9 | 85.5 | 254 | 629 |
| | | | 0.071 | 0.073 | 0.13 | 0.14 | 0.35 | 0.36 | 1.06 | 1.42 | 1.5 | 2.21 | 4.51 | 5.22 | 8.05 | 8.76 | 11.7 | 30.9 | 75.7 | 224.8 | 556.7 |
| Approx. weight | | kg lb | 0.26 | 0.27 | 0.42 | 0.44 | 0.71 | 0.74 | 1.2 | | 1.8 | | 3 | | 4.2 | | 5.6 | 8.2 | 23 | 32.6 | 45.5 |
| | | | 0.57 | 0.60 | 0.93 | 0.97 | 1.57 | 1.63 | 2.65 | | 3.97 | | 6.61 | | 9.33 | | 12.3 | 18.1 | 50.7 | 71.9 | 100.3 |
| Torsional rigidity | C_r | 10^3Nm/rad | 20 | 15 | 39 | 28 | 76 | 55 | 175 | 110 | 191 | 140 | 450 | 350 | 510 | 500 | 780 | 1304 | 3400 | 5700 | 10950 |
| Axial misalignment  | <i>max. values</i> | mm | 1 | 2 | 1 | 2 | 1.5 | 2 | 2 | 3 | 2 | 3 | 2.5 | 3.5 | 2.5 | 3.5 | 3.5 | 3.5 | 3.5 | 3 | 3 |
| Lateral misalignment  | <i>max. values</i> | mm | 0.15 | 0.2 | 0.2 | 0.25 | 0.2 | 0.25 | 0.2 | 0.25 | 0.25 | 0.3 | 0.25 | 0.3 | 0.3 | 0.35 | 0.35 | 0.35 | 0.4 | 0.4 | 0.4 |
| Axial spring stiffness | C_a | N/mm | 25 | 15 | 50 | 30 | 72 | 48 | 82 | 52 | 90 | 60 | 105 | 71 | 70 | 48 | 100 | 320 | 565 | 1030 | 985 |
| Lateral spring stiffness | C_r | N/mm | 475 | 137 | 900 | 270 | 1200 | 420 | 1500 | 435 | 2040 | 610 | 3750 | 1050 | 2500 | 840 | 2000 | 3600 | 6070 | 19200 | 21800 |

Max. angular misalignment 1.5°

Bellows coupling BC3

With conical connection

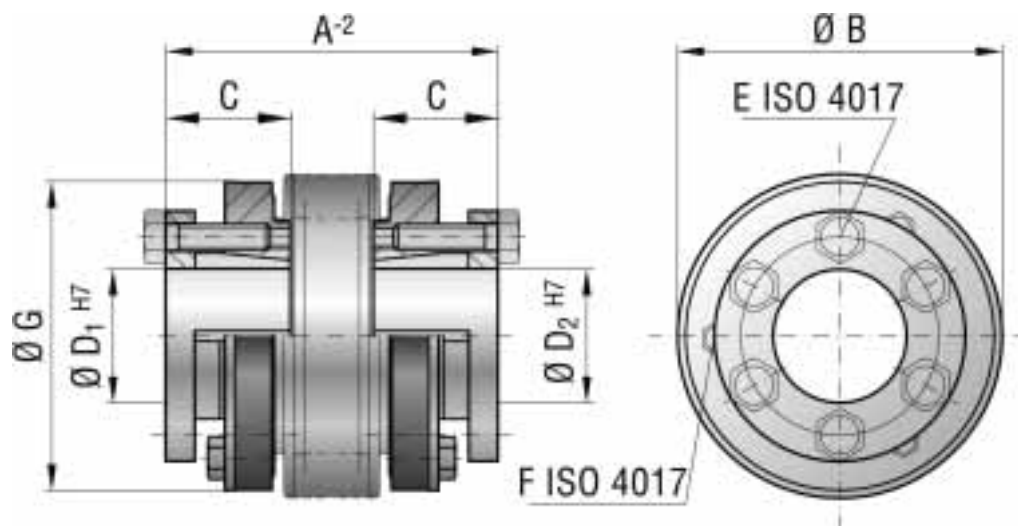

Bellows coupling for direct drives

Material:

Bellows made of highly flexible stainless steel.
Hub material: steel.

Design:

With split conical clamping hubs and strong, captive jack screws to ISO 4017.

Temperature range: -30 °C to +120°C (-22 °F to 248°F)

Backlash:

Completely backlash-free as a result of the frictional clamp connection.

Service life:

These torque limiters are permanent and maintenance-free as long as the performance limits are not exceeded.

Fit tolerance: Tolerance between shaft and hub 0.01–0.05 mm



Speeds:

Up to 10000 rpm / in excess of 10000 rpm with finely balanced version.

Brief overload: Acceptable up to 1.5 times the value specified.



EC2 – Bellows coupling

| | | | Series | | | | | | | | | | | | |
|--|-----------|--|--------|--------|--------|--------|--------|--------|--------|-------|------|-------|------|-------|------|
| | | | 2 | 4.5 | 10 | 15 | 30 | 60 | 80 | 150 | | 300 | | 500 | |
| Length options see ordering code | | | A | A | A | A | A | A | A | A | B | A | B | A | B |
| Rated torque | T_{KN} | Nm in.lb | 2 | 4.5 | 10 | 15 | 30 | 60 | 80 | 150 | | 300 | | 500 | |
| | | | 18 | 40 | 89 | 133 | 266 | 531 | 708 | 1328 | | 2655 | | 4425 | |
| Overall length | A | mm | 30 | 40 | 44 | 58 | 68 | 79 | 92 | 92 | | 109 | | 114 | |
| Outer diameter | B | mm | 25 | 32 | 40 | 49 | 56 | 66 | 82 | 82 | | 110 | | 123 | |
| Fit length | C | mm | 10.5 | 13 | 13 | 21.5 | 26 | 28 | 32.5 | 32.5 | | 41 | | 42.5 | |
| Inner diameter from \varnothing to \varnothing H7 | D_1/D_2 | mm | 4–12.7 | 6–16 | 6–24 | 8–28 | 12–32 | 14–35 | 16–42 | 19–42 | | 24–60 | | 35–62 | |
| Fastening screws to ISO 4762 | E | | M3 | M4 | M4 | M5 | M6 | M8 | M10 | M10 | | M12 | | M16 | |
| Tightening torque of fastening screw | E | Nm in.lb | 2.3 | 4 | 4.5 | 8 | 15 | 40 | 70 | 85 | | 120 | | 200 | |
| | | | 21 | 36 | 40 | 71 | 133 | 354 | 620 | 753 | | 1062 | | 1770 | |
| Distance between centers | F | mm | 8 | 11 | 14 | 17 | 20 | 23 | 27 | 27 | | 39 | | 41 | |
| Distance | G | mm | 4 | 5 | 5 | 6.5 | 7.5 | 9.5 | 11 | 11 | | 13 | | 17 | |
| Moment of inertia | J | 10^{-3}kgm^2 10^{-3}in.lb.s^2 | 0.002 | 0.007 | 0.016 | 0.065 | 0.12 | 0.3 | 0.75 | 1.8 | 0.8 | 7.5 | 3.8 | 11.7 | 4.9 |
| | | | 0.0018 | 0.0062 | 0.0142 | 0.0575 | 0.1062 | 0.2655 | 0.6638 | 1.59 | 0.71 | 6.64 | 3.36 | 10.36 | 4.34 |
| Hub material | | | Al | Al | Al | Al | Al | Al | Al | Steel | Al | Steel | Al | Steel | Al |
| Approx. weight | | kg lb | 0.02 | 0.05 | 0.06 | 0.16 | 0.25 | 0.4 | 0.7 | 1.7 | 0.75 | 3.8 | 1.6 | 4.9 | 2.1 |
| | | | 0.044 | 0.110 | 0.132 | 0.353 | 0.551 | 0.882 | 1.54 | 3.75 | 1.65 | 8.38 | 3.53 | 10.80 | 4.63 |
| Torsional rigidity | C_T | 10^3Nm/rad | 1.5 | 7 | 9 | 23 | 31 | 72 | 80 | 141 | | 157 | | 290 | |
| Axial misalignment  | | max. values mm | 0.5 | 1 | 1 | 1 | 1 | 1.5 | 2 | 2 | | 2 | | 2.5 | |
| Lateral misalignment  | | max. values mm | 0.2 | 0.2 | 0.2 | 0.2 | 0.2 | 0.2 | 0.2 | 0.2 | | 0.2 | | 0.2 | |
| Axial spring stiffness | C_a | N/mm | 8 | 35 | 30 | 30 | 50 | 67 | 44 | 77 | | 112 | | 72 | |
| Lateral spring stiffness | C_r | N/mm | 50 | 350 | 320 | 315 | 366 | 679 | 590 | 960 | | 2940 | | 1450 | |

Max. angular misalignment 1°

Bellows coupling EC2

With clamping hub

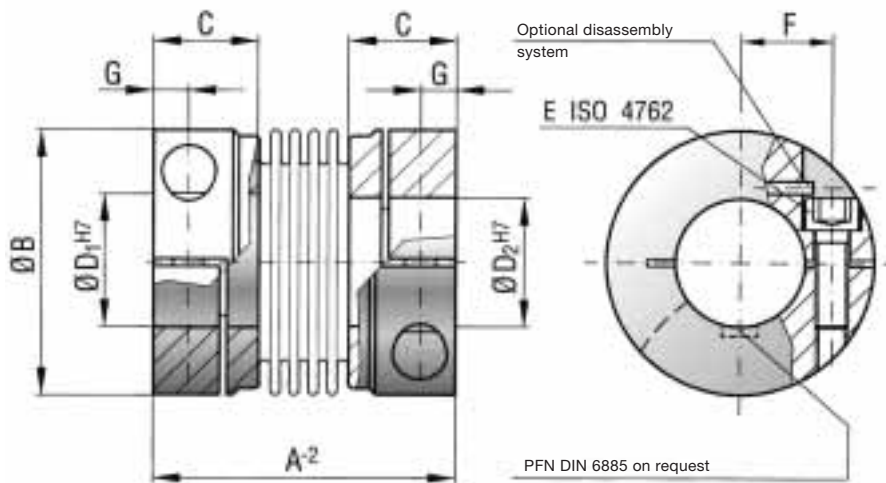

Bellows coupling for direct drives

Material:

Bellows made of highly flexible stainless steel.
Hub material: see table below.

Design:

With clamping hubs and a single lateral screw to ISO 4762.

Temperature range: -30 °C to +100°C (-22 °F to 212 °F)

Backlash:

Completely backlash-free as a result of the frictional clamp connection.

Service life:

These torque limiters are permanent and maintenance-free as long as the performance limits are not exceeded.

Fit tolerance: Tolerance between shaft and hub 0.01 – 0.05 mm

Optional self-opening clamp system:

For expanding the bore hole during assembly or dismantling.



Accessories and supplementary instructions

Torque adjusting wrench for DIN 1816 nuts

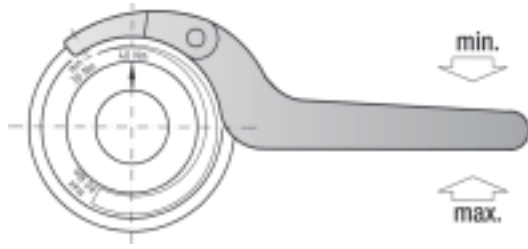

Smaller coupling sizes do not require a torque adjusting wrench. The adjusting nuts for the 1.5/2/4.5/10 series can be adjusted with a bolt or pin.

| Series | Torque adjusting wrench | |
|--------|-------------------------|----------------------------|
| | Standard version | Full disengagement version |
| 15 | AC 20047730 | AC 20047730 |
| 30 | AC 20047731 | AC 20047731 |
| 60 | AC 20047732 | AC 20047749 |
| 80/150 | AC 20047733 | AC 20047733 |
| 200 | AC 20047734 | AC 20047750 |
| 300 | AC 20047735 | AC 20047735 |
| 500 | AC 20047736 | AC 20047736 |
| 800 | AC 20047737 | AC 20047751 |
| 1500 | AC 20047738 | AC 20047738 |
| 2500 | AC 20047739 | AC 20047752 |

Mechanical limit switch (emergency cut-off)

Dimension drawings

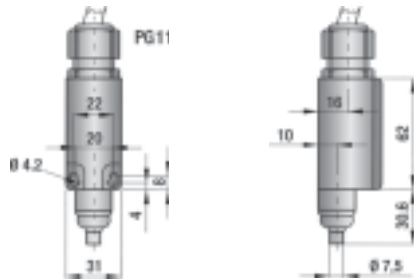

Important:
Always carry out a 100 % test of the switch function after assembly.

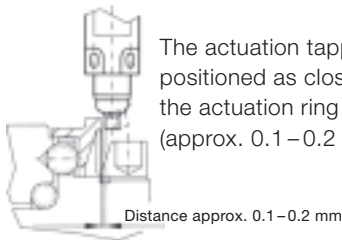

The actuation tappet should be positioned as close as possible to the actuation ring of the torque limiter (approx. 0.1–0.2 mm).

| Technical data | |
|------------------------|-------------------------------|
| Max. voltage: | 500 V AC |
| Max. constant current: | 10 A |
| Degree of protection: | IP 65 |
| Contact type: | NC contact (positive opening) |
| Ambient temperature: | -30 °C to +80 °C |
| Actuation: | Tappet (metal) |
| Circuit symbol: | |

The mechanical limit switch is suitable for size 30 and above.

Proximity switch (emergency cut-off)

Dimension drawings

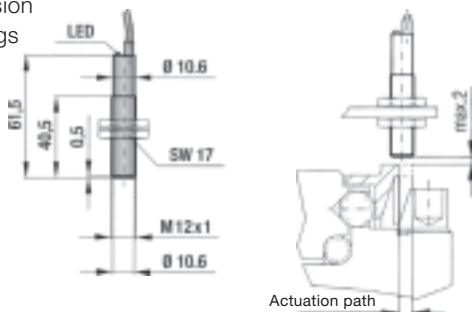

Important:
Always carry out a 100 % test of the switch function after assembly.

| Technical data | |
|---------------------------|------------------|
| Voltage range: | 10 to 30 V DC |
| Max. output current: | 200 mA |
| Max. switching frequency: | 800 Hz |
| Temperature range: | -25 °C to +70 °C |
| Degree of protection: | IP 67 |
| Switch type: | PNP NC contact |
| Detection gap: | max. 2 mm |
| Circuit symbol: | |

Assembly instructions for low backlash torque limiters

For the TL 1 – TL 3 models, the fit tolerance between the shaft and hub must be between 0.01 and 0.05 mm. Ensure that the coupling hub mounts smoothly on the shaft prior to assembly. Lightly oil the shaft prior to assembly. Do not use oils or grease with sliding additives (for example, MoS₂). Any keyways in the shaft will not affect the functioning of the clamp connection.

Model TL1 has an integrated **bearing (1)** for the attached component (for example, a pulley or sprocket wheel). Do not exceed the **maximum radial force (2)**, (see table). By centering the load between the **dimension (S)**, sufficient force is applied between the two balls and no separate bearings are required. Additional bearings are required for offset mounting. This is recommended, for example, if the attached component has a very small diameter or a very large width. Ball bearings, needle bearings or bushings can be used depending on the installation situation.

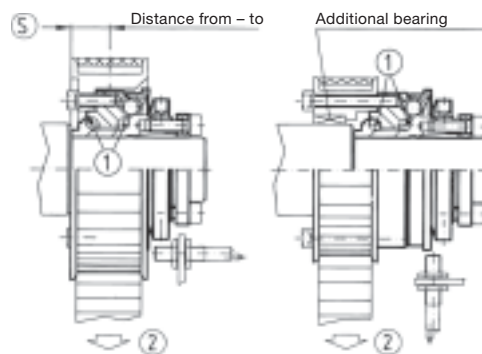

| Series | 1.5 | 2 | 4.5 | 10 | 15 | 30 | 60 | 150 | 200 | 300 | 500 | 800 | 1500 | 2500 |
|-------------------------------|-----|-----|------|------|------|-------|-------|-------|-------|-------|-------|-------|-------|-------|
| Max. radial load capacity (N) | 50 | 100 | 200 | 500 | 1400 | 1800 | 2300 | 3000 | 3500 | 4500 | 5600 | 8000 | 12000 | 20000 |
| (S) from – to | 3–6 | 5–8 | 5–11 | 6–14 | 7–17 | 10–24 | 10–24 | 12–24 | 12–26 | 12–28 | 16–38 | 16–42 | 20–50 | 28–60 |

Adjustment of the disengagement torque

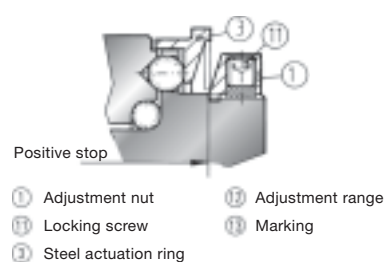
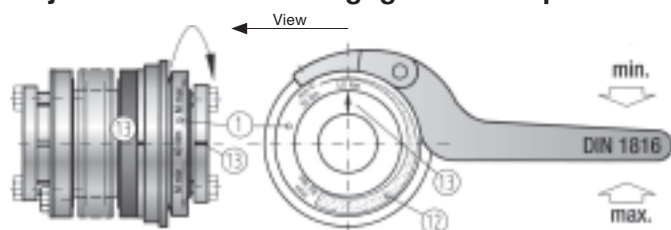

WITTENSTEIN alpha torque limiters are factory adjusted to the specified disengagement torque, which is marked on the coupling. The adjustment range (min./max.) is indicated on the **adjustment nut (1)**. The customer can adjust the disengagement torque infinitely within the **adjustment range (12)** by varying the pretension of the disc springs. The adjustment range must not be exceeded during the adjustment process. After loosening the **lock screw (11)**, the disengagement torque can be adjusted using a suitable tool, e.g. a torque adjusting wrench to DIN 1816. The three locking screws **(11)** should then be tightened again.

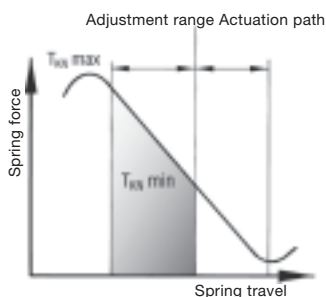

Important!

WITTENSTEIN alpha torque limiters incorporate disc springs with special spring characteristics. Never exceed the max./min. range of the disengagement torque, which is located along the downward slope of this characteristic curve.